

HSS

Parcel Belt Conveyor

Designed for the parcel handling industry, for singulated flow application.

- 8-5/8" Drive Pulley
- Bolted Construction
- 4" Tail Roller
- 3-15 HP available
- 19" Take-Up Length
- 110' Maxium Overall Conveyor Length
- 250 - 600 FPM

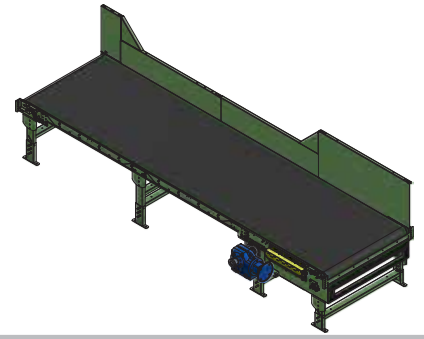

	Bed Width		
	37"	43"	49"
Drive (Center)	1258	1677	1667
Drive (End)	1258	1677	1667
Intermediate Bed (10')	285	315	345
Tail Assembly	166.5	193.5	220.5
Nose-over Assembly	158	182	158

Notes:
 Above weights included 12" high side guard.
 Accessories, crating, etc. are not included in above weights.
 Customer specified guarding available per order.

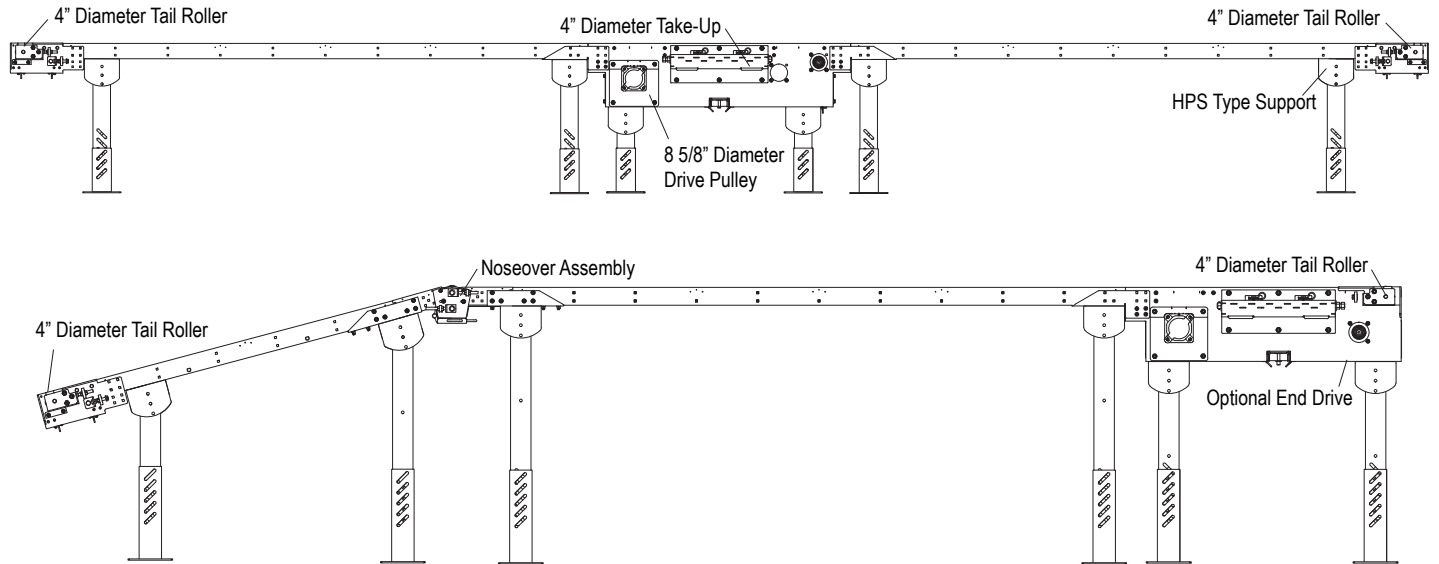

• STANDARD SPECIFICATIONS

BELT—Belting available per customer specification.

BED—3 1/2" deep 10 ga. or 12 ga. formed steel slider bed painted per customer specified color.

CENTER DRIVE—Minimum elevation 15 1/2"

DRIVE PULLEY—8 5/8" diameter lagged pulley with through shaft design.

TAKE-UP ROLLER—4" diameter ROL-07S

SNUB IDLER—2 3/4" diameter ROL-02

TAIL PULLEY—4" diameter ROL-07S

DRIVE BEARINGS—Sealed, pre-lubricated, self-aligning, cast-iron ball bearing.

MOTOR—Available from 3 to 15 HP.

BELT SPEED—Available from 250 to 540 FPM.

CAPACITY—100 lbs. per linear foot. Do not exceed capacity in chart below.

HP Selection Chart

		LENGTH				
		15'	25'	50'	75'	110'
SPEED (FPM)	250	2	3	3	5	5
	300	2	3	3	5	7.5
	350	2	5	5	5	7.5
	450	3	3	5	7.5	10
	540	3	3	5	7.5	15

Note: HP calculations based on 6000 PPH. For higher rate, contact factory.

• OPTIONAL EQUIPMENT

FLOOR SUPPORTS—Available with a wide range of adjustment. Specify top of belt elevation. One support required at every bed joint and ends of conveyor. Holes in feet for lagging to floor. Knee bracing not included.

BELT—Option per customer specifics.

UNDERSIDE BED COVERS—Hinged expanded metal per customer specifics.

NOSEOVER—Single noseover for transition from angled to horizontal position.

TAIL ROLLER—4" diameter ROL-07SX (Spherical Roller Bearings)

BEDS—Available in 6 5/8" deep (12 ga.)

CABLE RAIL ASSEMBLY—For mounting cable

MOTORS—2, 3, 5, 7 1/2, 10, and 15 available.

SIDE GUARDS/PAN—Available in 2" to 36" high (2" increments)

SLAVE TAKE-UP—Available in all widths, for scanning applications.