

PDS

Product Data Sheet

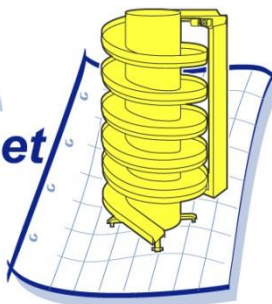

SpiralVeyor® SVs Series

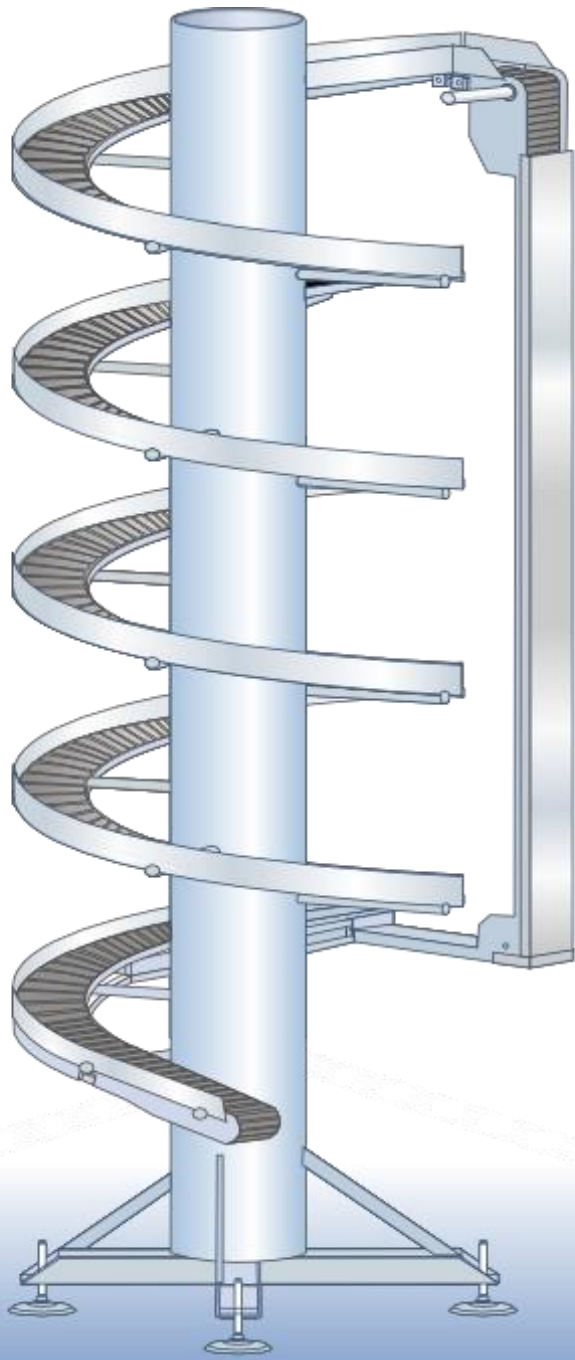

- 1
Frame
- 2
Belt
- 3
Guides
- 4
Accessories
- 5
Packages
- 6
Application
- 7
Documentation

Introduction



1

Frame

2

Belt

3

Guides

4

Accessories

5

Packages

6

Application

7

Documentation

How to read this document

This Product Data Sheet describes the relevant standard features, options, accessories and approved application of the SpiralVeyor®

Many special applications and features can be designed on customer demand to complete customized SpiralVeyor® products by our Engineered Product program. So if your feature or application is not mentioned in this document ask us for the possibilities at



Thanks to the large installed base, our decades of experience and our library of concepts we can satisfy almost all requests.

Index

To increase the readability and focus the content, the SpiralVeyor® Product Data Sheet is build-up in different chapters.

- [SpiralVeyor® General](#)

This chapter deals with all general information that is applicable to most of the below chapters.

- [SpiralVeyor® SVs](#)

This chapter deals with the specific extra information, parameters and options for small conveyor widths ranging from 100 up to 200 mm belt widths. Typically applied for single file container handling and primary packaging.

- [SpiralVeyor® SV](#)

This chapter deals with the specific extra information, parameters and options for medium conveyor widths ranging from 200 up to 600 mm belt widths. Typically applied for logistics and secondary packaging

- [SpiralVeyor® SVe](#)

This chapter deals with the specific extra information, parameters and options for extra wide conveyor widths ranging from 600 and wider widths. Type SVe is build up from more co-operating parallel belt tracks building one wider common conveyor belt for large items or mass flow of single items. Typically applied for logistics, parcels and luggage

- [SpiralVeyor® SVM](#)

This chapter deals with the specific extra information, parameters and options for the spiral conveyor with a belt build up from one or more co-operating belt tracks. Herewith it creates a larger common and stable conveyor surface especially suited for container mass flow applications. Typically applied for mass flow bottling and canning.

- [SpiralVeyor® SVo](#)

This chapter deals with the specific extra information, parameters and options for transportation of uniform sized plastic totes.

Introduction



1

Frame

2

Belt

3

Guides

4

Accessories

5

Packages

6

Application

7

Documentation

Technical specifications

In case of a proposal quoted or order confirmed, this document and the linked serve as the base for the application and technical features. The separate quotation or order confirmation includes technical specifications (📄) listing up the options from this document. The technical specifications may describe extra features, special design or applications which are only available upon request. The technical specifications in the proposal quoted or order is leading and overrules this product sheet.

Not all options and configuration can be combined. In case an impossible combination is requested the AmbaFlex sales engineering department will inform you and suggest a better configuration or combination.

Legend:

Example Picture:

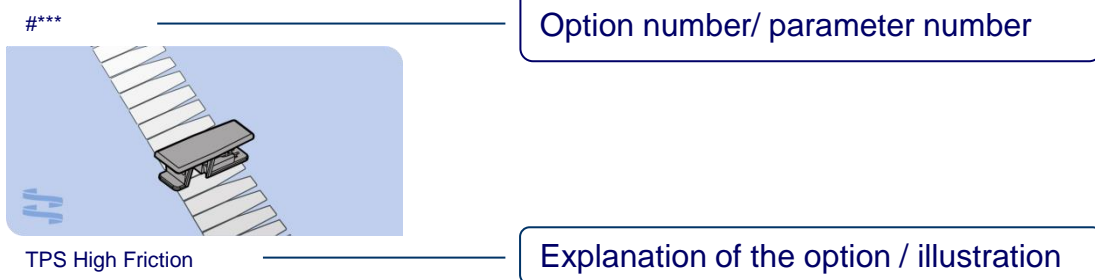

📄 = Symbol referring to the Technical Specification in quotation or order confirmation

⚠️ = May need additional explanation/ measures to comply with the CE regulations.

📄 = link to a pdf document with additional information/explanation.

📄 = link to an accompanying autocad drawing.

* Disclaimer:

Illustrations shown are indicative. Illustrations can differ on details for the supply. Illustrations may show options that are not in the scope of supply unless specified in the quotation / order.

All dimensions specified in this document are design dimensions. As for the build dimensions, larger functional tolerances should be considered.

The latest Product Data Sheet for this machine is available through the hyperlink below.

http://www.ambaflex.com/downloads/SVs_PDS_EN.pdf

Frame SV



1

Frame

2

Belt

3

Guides

4

Accessories

5

Packages

6

Application

7

Documentation

A) Footprint dimensions* for SVs

Single track

#560

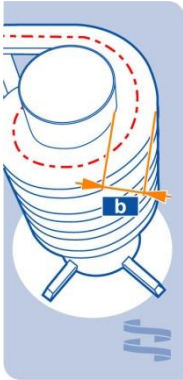

Belt width
b

#561

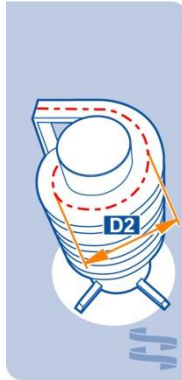

Centerline diameter
D2

#562



Footprint
X1 and X2

Belt b [mm]	Central diameter D2 [mm]							
	Compact		Medium			Large		
	850	900	1500	1560	1600	2000	2060	2100
100	990 x 990*				1740 x 1740*			2240 x 2240*
140		1080 x 1130*		1740 x 1740*			2240 x 2240*	
200			1740 x 1740*			2240 x 2240*		

*) Footprint X1 x X2

*) Excluding side guide, drive and options

B) Footprint dimensions* for SVs X

Multi track

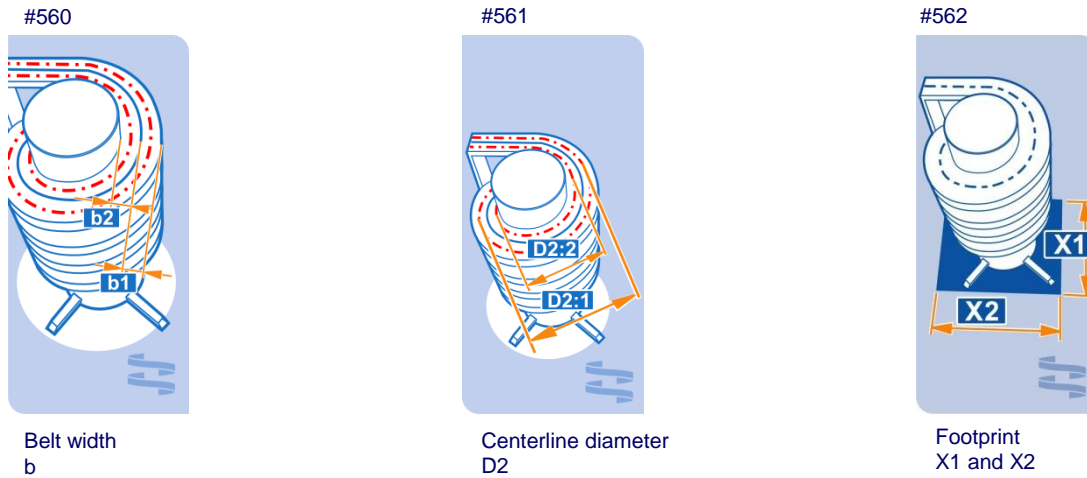

Compact

Belts b1, b2 [mm]	Central Track Diameter				Footprint X1, X2 [mm]
	D2.1 [mm]	D2.2 [mm]	D2.3 [mm]	D2.4 [mm]	
2/100	1134	850			1274 x 1274
3/100	1418	1134	850		1558 x 1558
4/100	1702	1418	1134	850	1842 x 1842
2/140	1264	900			1444 x 1444
3/140	1628	1264	900		1808 x 1808
2/200	1500	1016			1740 x 1740

Applies to Standard track build up
Explanation: 2/140 = 2x tracks with a belt width of 140 mm each.

Large

Belts b1, b2 [mm]	Central Track Diameter				Footprint X1, X2 [mm]
	D2.1 [mm]	D2.2 [mm]	D2.3 [mm]	D2.4 [mm]	
2/100	2100	1816			2240 x 2240
3/100	2100	1816	1532		2240 x 2240
4/100	2100	1816	1532	1248	2240 x 2240
2/140	2060	1696			2240 x 2240
3/140	2060	1696	1332		2240 x 2240
4/140	2060	1696	1332	968	2240 x 2240
2/200	2000	1516			2240 x 2240
3/200	2000	1516	1032		2240 x 2240
4/200	2700	2216	1732	1248	2940 x 2940

Applies to Standard track build up
Explanation: 2/140 = 2x tracks with a belt width of 140 mm each.

*) Excluding side guide, drive and options

B) Lower end

Inclined

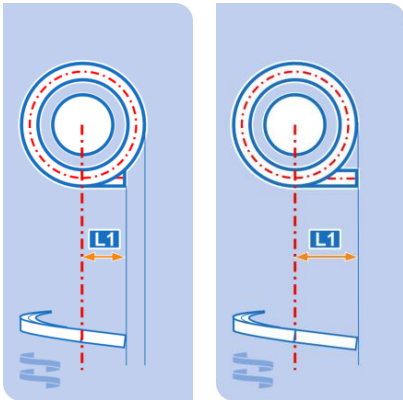

#427 = L1, Total lower-end length
 #428 = L2, Horizontal lower-end length

Horizontal

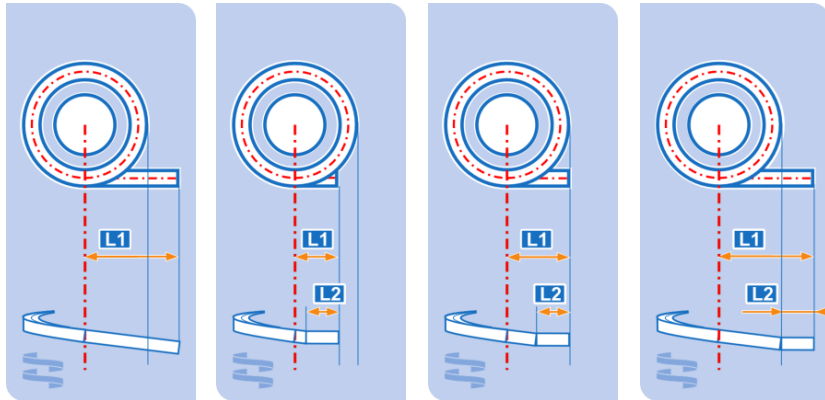

L1 ≥ 540mm
 L2 = 0mm, L2 ≥ 540mm

#435

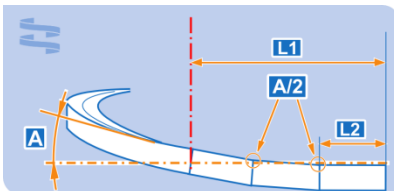

Double bend

#436

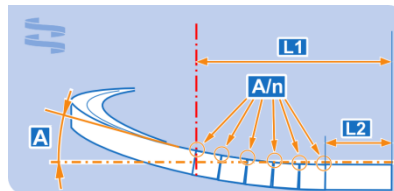

Smooth bend
 Picture -> n = 6

#946

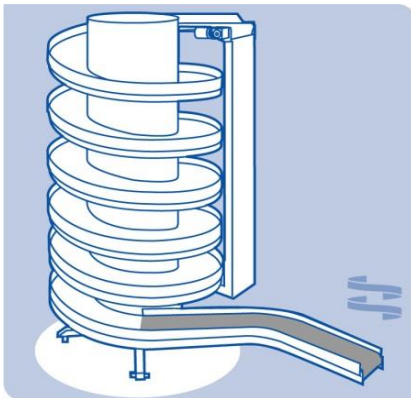

Q shaped

#945



Various shapes

C) Upper end

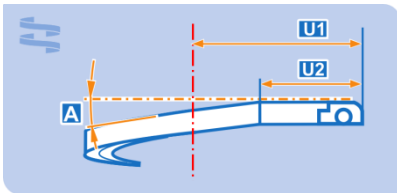

#433 = U1, Total upper-end length
 #434 = U2, Horizontal upper-end length $U2 \geq 300\text{mm}$

#437

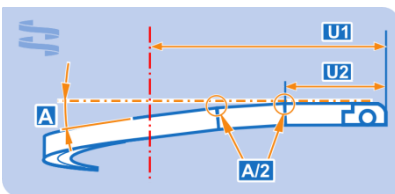

Double bend

#439

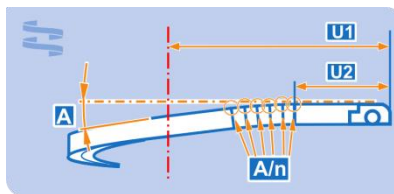

Smooth bend
 Picture -> n = 6

#441

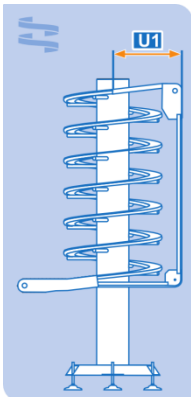

Direct return
 $U1 \geq 590\text{ mm}$

#455

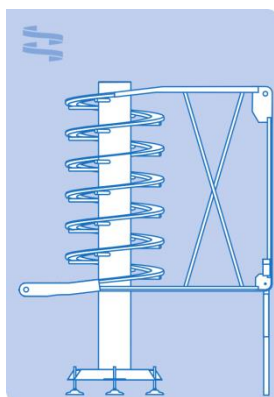

Extended upper-end

#445

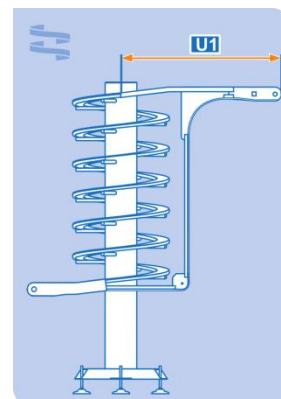

Extended direct return
 $U1 \geq 1555\text{ mm}$

#484

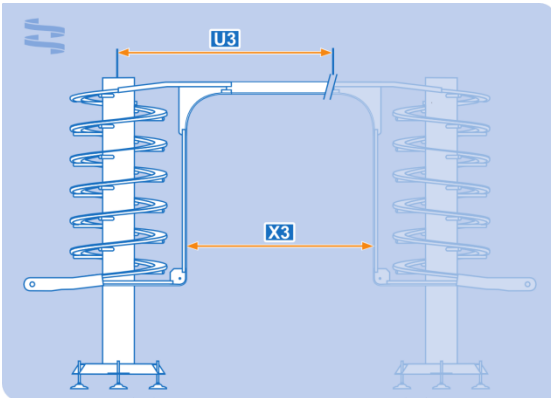

Portal left tower
 $U3 \geq 1010 \text{ mm}$, $X3 \geq 840 \text{ mm}$

#485

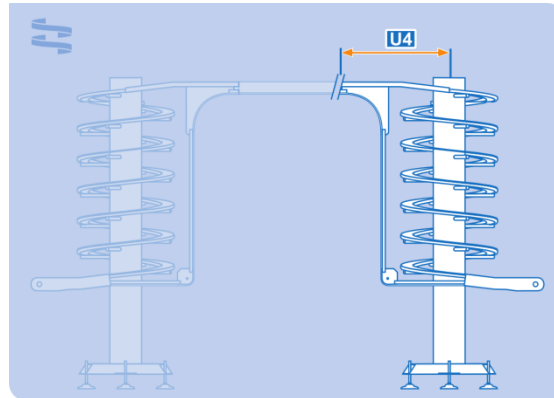

Portal right tower
 $U4 \geq 1010 \text{ mm}$

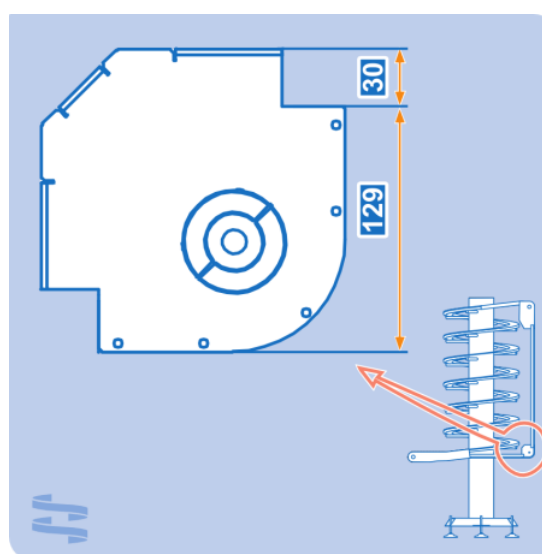
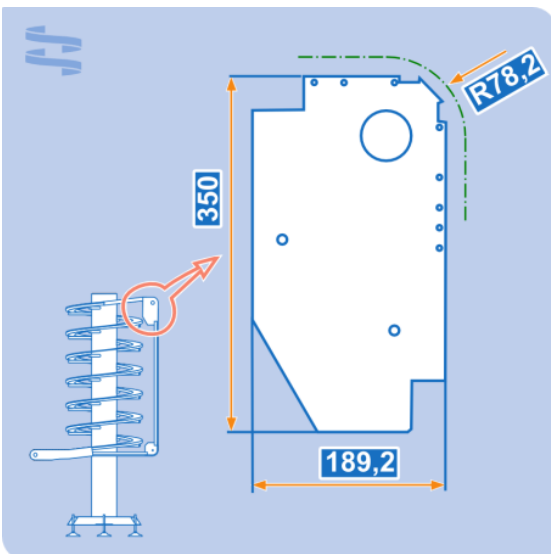
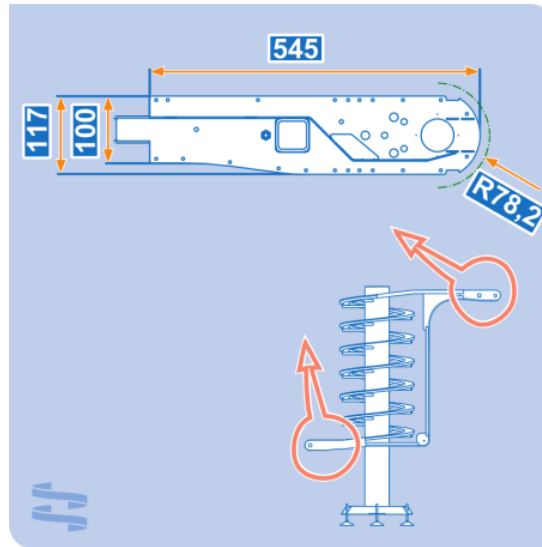
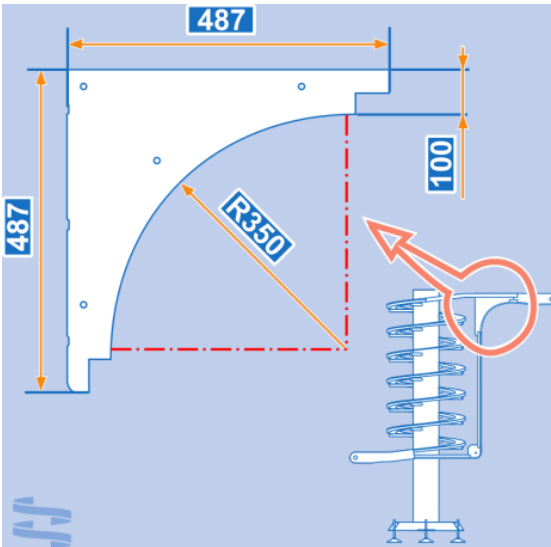

D) Multi Track Spacing

1) #422

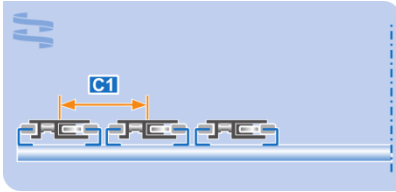

Standard track spacing
 $C1 = (b1)/2 + 42 + (b2)/2$

2) #423

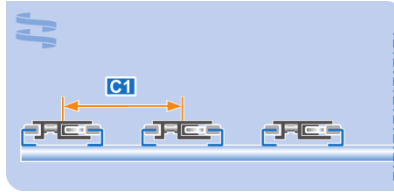

Wide track spacing
 $C1 = (b1)/2 + 101 + (b2)/2$

3) #403

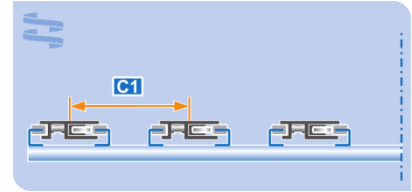

Customized track spacing
 $C1 = (b1)/2 + >101 + (b2)/2$

4) #424

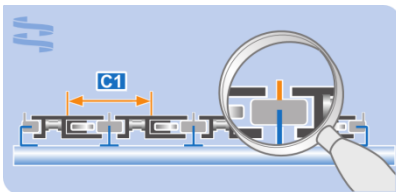

Compact track spacing, integrated guide
 $C1 = (b1)/2 + 11 + (b2)/2$

5) #425

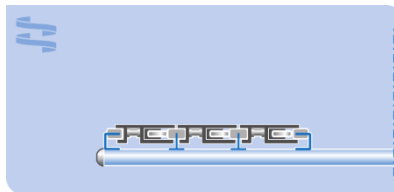

Compact track spacing
 $C1 = (b1)/2 + 2 + (b2)/2$

E) Track Build Up

#941

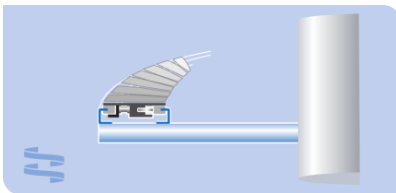

Compact track build up

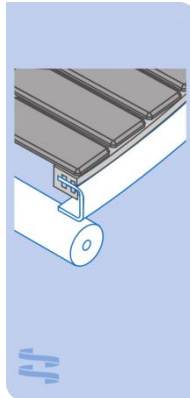

#342

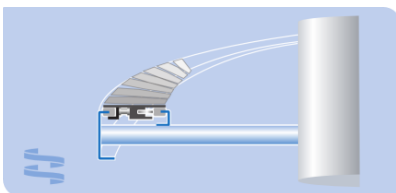

Heavy duty track build up

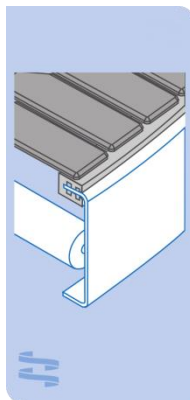

#462

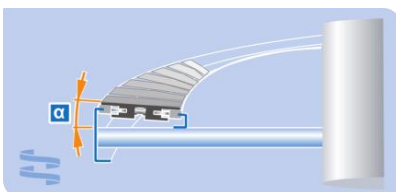

Banking

F) Connections

#702

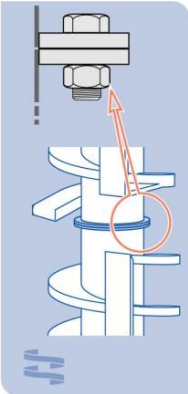

Flange

#953

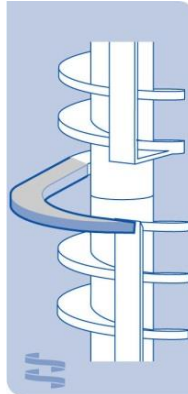

Connection loop

G) Clearance options

#686

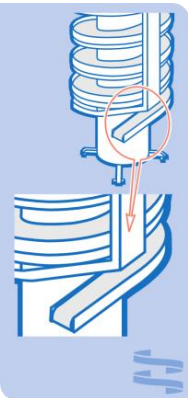

Angular return channel

#689

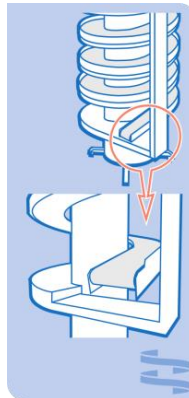

Crossover Return

#487

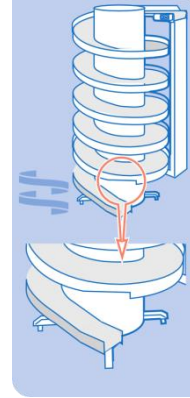

Cutout lower-end

A) B-guides

stainless steel

Outer

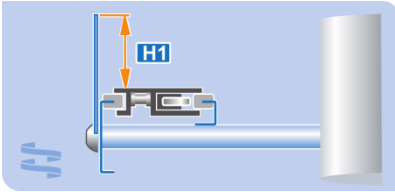

- #292 H1 = 50mm
- #281 H1 = 100mm
- #283 H1 = 175mm
- #282 H1 = 250mm

Intermediate

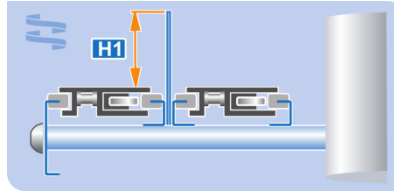

- #293 H1 = 61mm
- #284 H1 = 111mm

Inner

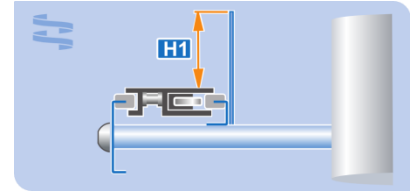

- #293 H1 = 61mm
- #284 H1 = 111mm

#194

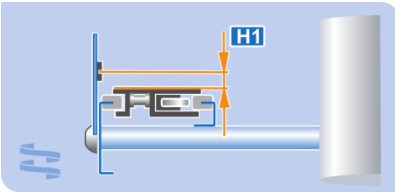

B-Guide + strip, centre strip xx mm top of belt

#202

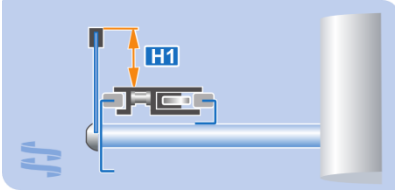

- B-Guide + cap, H1 = 55mm
- B-Guide + cap, H1 = 105mm

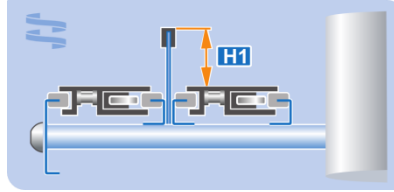

- B-Guide + cap, H1 = 66mm
- B-Guide + cap, H1 = 116mm

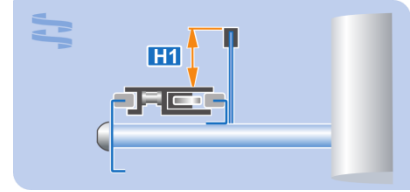

- B-Guide + cap, H1 = 66mm
- B-Guide + cap, H1 = 116mm

B) BG-guides

Bottling guide

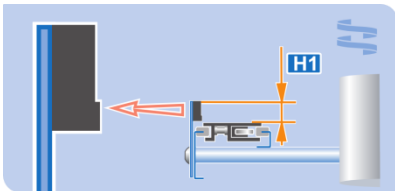

#405 Outer BG40-Guide, H1 = 45-64mm

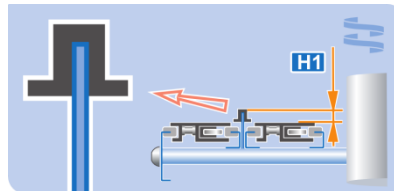

#406 Intermediate BG40-Guide, H1 = 66mm

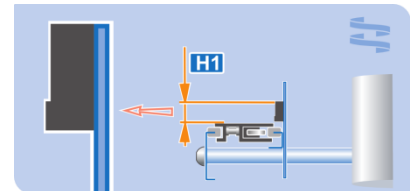

#407 Inner BG40-Guide, H1 = 45-64mm

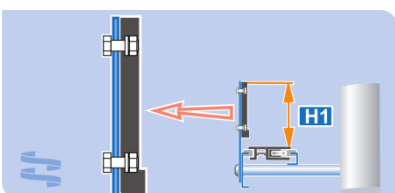

- #408 Outer BG75-Guide, H1 = 80-99mm
- #410 Outer BG150-Guide, H1 = 155-174mm

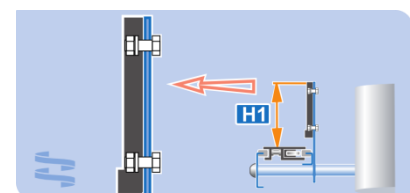

- #409 Inner BG75-Guide, H1 = 80-99mm
- #411 Inner BG150-Guide, H1 = 155-174mm

Guides



C) Special guides

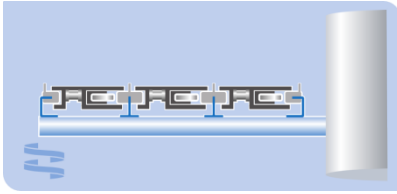

Integrated guide

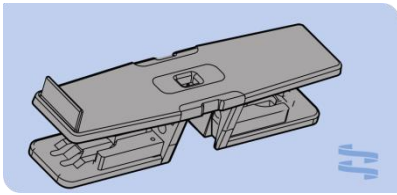
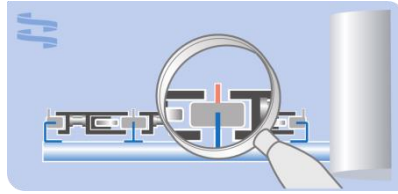

Outer tip guide*

*) available for SVs 100 and 140

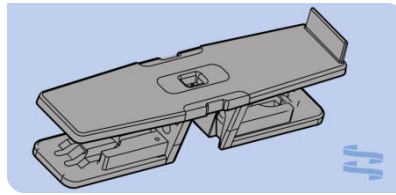

Inner tip guide*

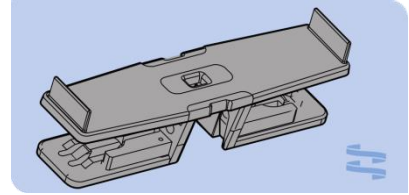

Twin tip guide*

1

Frame

2

Belt

3

Guides

4

Accessories

5

Packages

6

Application

7

Documentation

D) Separation guides

stainless steel

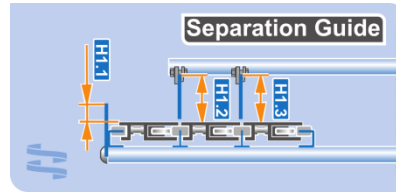
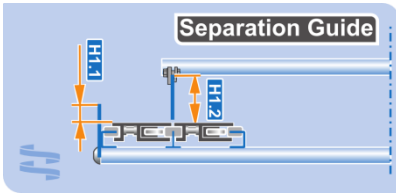

E) Offset options

#915

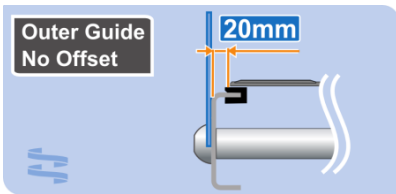

#781

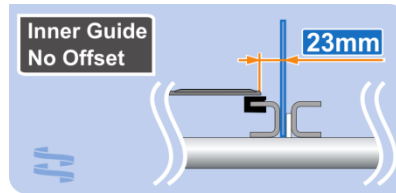

#770

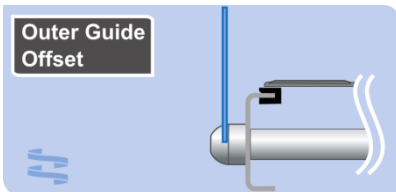

#771

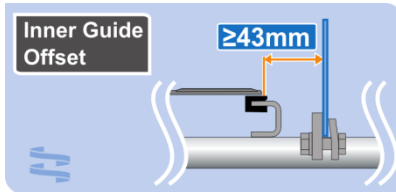

Offset spacers: 10/15/25mm

Picture -> 25mm offset

C) Guide location radius

#695

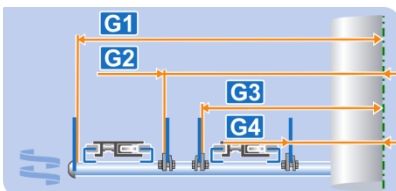

F) Column space

#928

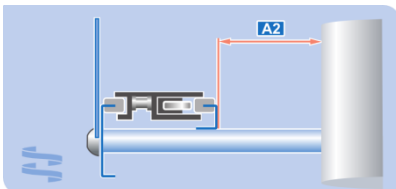

G) No guides

#294



H) Column style

#933

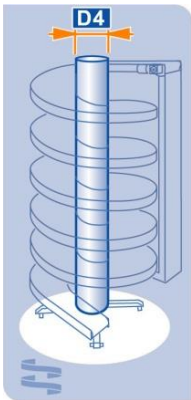

Frame column, tube style

Economic solution for average application

#563

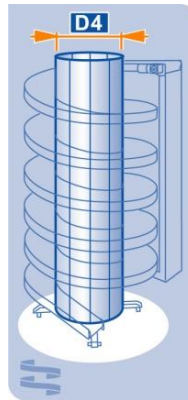

Frame column, full size

Heavy duty frame for tall and demanding applications

I) Open frame style

#468

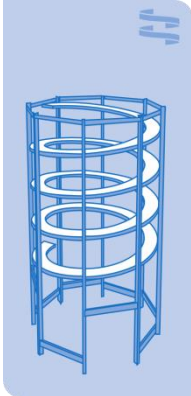

Outer frame

#469

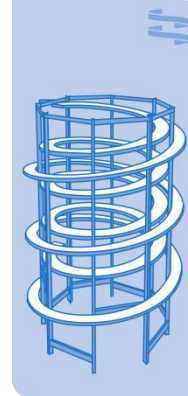

Intermediate/ centre frame
Picture -> W1=3, W2=4

Accessories SVs



1

Frame

2

Belt

3

Guides

4

Accessories

5

Packages

6

Application

7

Documentation

A) Transfer options

#489

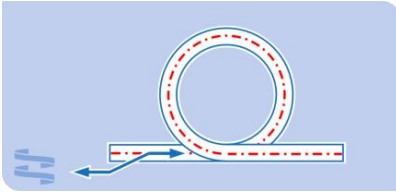

Lower end: Side transfer outer side

#490

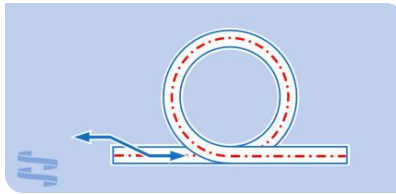

Lower end: Side transfer inner side

#491

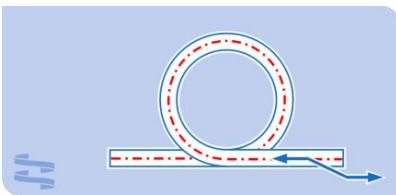

Upper end: Side transfer outer side

#492

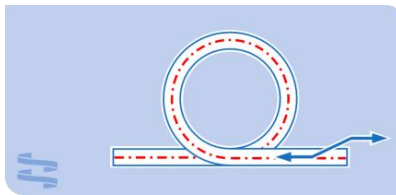

Upper end: Side transfer inner side

#493

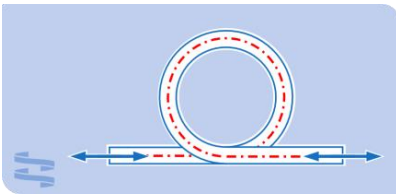

Head to head transfer

#446

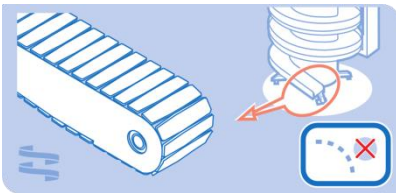

Head to head transfer:
No extra product transfer provisions

#449

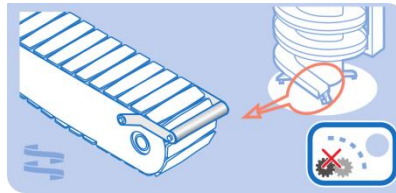

Head to head transfer:
Product transfer rollers 25mm, stainless steel (non driven)

#451

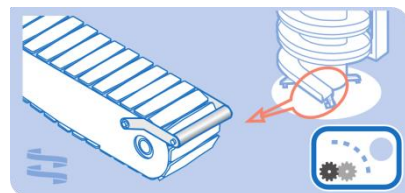

Head to head transfer:
Product transfer rollers 25mm, stainless steel (driven)

#760

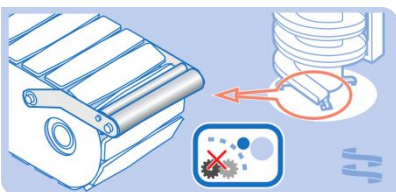

Head to head transfer:
Product transfer micro roller set 12/25mm, stainless steel (driven)

#661

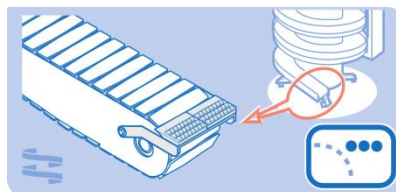

Head to head transfer:
Product transfer plate with rollers (non driven)

B) Guarding

#684

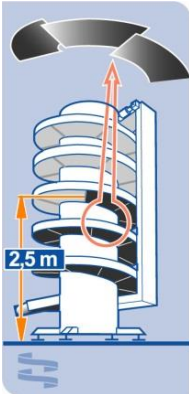

Belt guarding
Partial PS
underguarding

#683

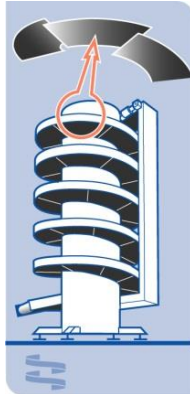

Belt guarding.
Full height PS
underguarding

#693

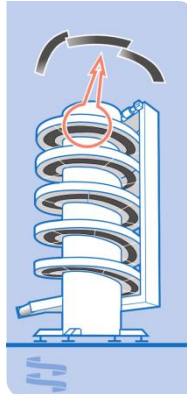

Chain guarding.
Full height PS
underguarding

#952

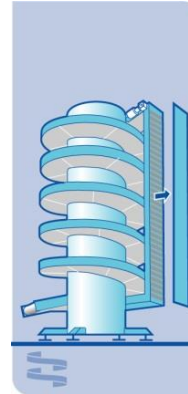

Return guarding
in spiral finish



C) Extra service access

#735

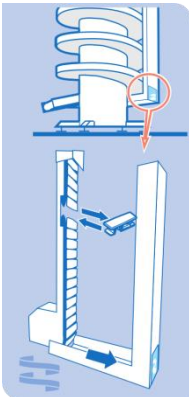

Transparent panel
Opening for exchanging
slats

#261

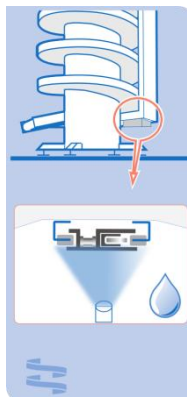

D) Cleaning options

E) Drive positions

#204

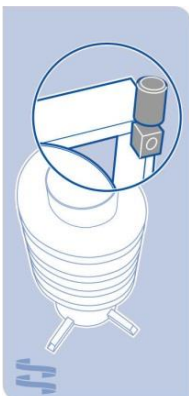

Upper end. Inside

#205



Upper end. Outside

Integration / Application



1

Frame

2

Belt

3

Guides

4

Accessories

5

Packages

6

Application

7

Documentation

A) Capacity

#970

Load per meter



#968

Load per item



#969

Point load



Speed

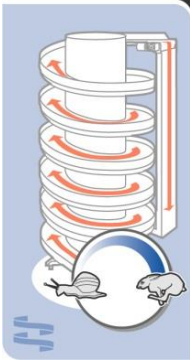

The design frequency range is 18-50hz.

Specials on request.

Max. elevation

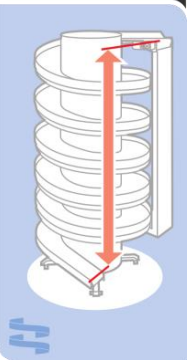

Basically unlimited. Depending on the application, see □.

B) Products

#984

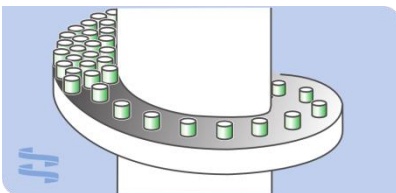

Accumulation

#982

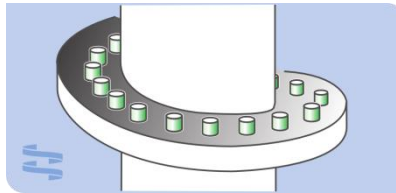

Spacing

#983

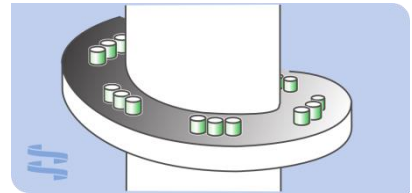

Indexing

C) Integration

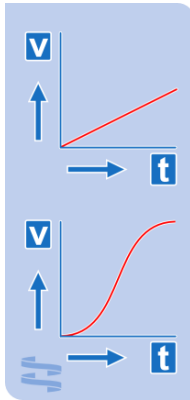
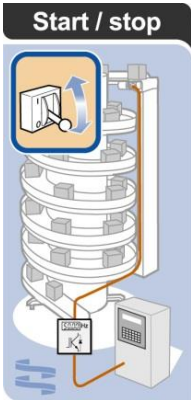

The SpiralVeyor® is designed to run continuously. In case of start/ stop or indexing operation a frequency inverter is required.

In those cases the acceleration and deceleration time must be set as following:

Linear controls velocity
 $t [s] = 1,5 * v [m/min]/30$

S-curve controls velocity to limit acceleration and deceleration
 $t [s] = 1,5 * v [m/min]/60$

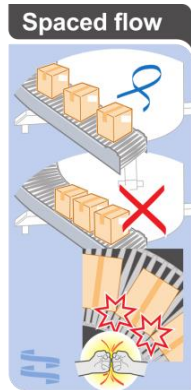

Goods should arrive at the SpiralVeyor® with a recommended minimum spacing of 1/3rd of their length

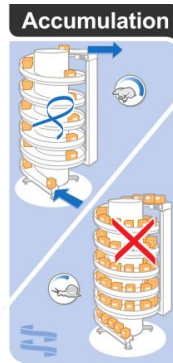

#*984

The SpiralVeyor® is designed for transporting goods up or down. Only if specified and as recommended in the □, the SpiralVeyor® can be used as an accumulator or buffer. For specialized accumulation concepts see our website at www.accuveyor.com.

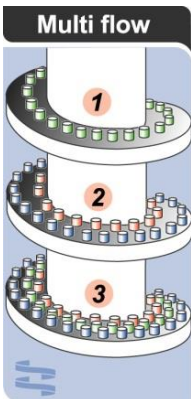

#524

The SpiralVeyor® is standard designed to handle a single stream of products. More parallel rows are possible if mentioned in the □.

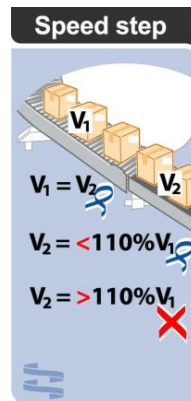

Ideally the speed of the connection conveyor should be similar to the spiral belt speed. If that is not practical a speed difference of less than 10% will be allowed. Notice that speed differences will affect the life time of the belt. The SpiralVeyor® may never be used to pull the required gaps between the goods. In case of a special application we refer to the □.

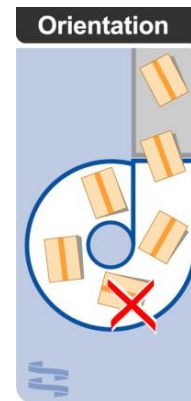
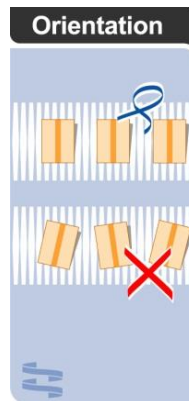

Products should arrive at the SpiralVeyor® orientated in the direction of flow. Otherwise jamming may occur. Never force an orientation change on the SpiralVeyor® but use upstream conveyors for that purpose. In case of a special application we refer to the □.

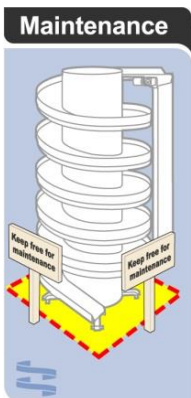

We refer to our installation instructions supplied with the SpiralVeyor® for appropriate maintenance access. We recommend to keep that space around the machine free of obstacles. In case the space is not available, maintenance may require more time.