



BestFlex Power BFP 1.5 and BFP 1.9 Conveyor System with Accumulation

Operator's Manual

FMH Conveyors LLC
107 Flint Street
Jonesboro, AR 72401

p. 800.327.9209
t. 844.FMH.SERVICE
f. 870.935.3661

Part Number 99042
Effective October 2015
www.fmhconveyors.com

FMH Conveyors Operator's Manual
BestFlex BFP 1.5 and BFP 1.9

Dear Operator,

We at FMH Conveyors would like to thank you for selecting our BestFlex® power conveyor system as the solution to your conveying needs.

Your BestFlex® system is supported by a group of factory trained customer service representatives. They can be reached via our toll free number **1-800-327-9209**. Whether your needs require assistance from the factory or in the field, please do not hesitate to call. Our team is eager to help.

Thank you once again for purchasing our BestFlex conveyor system. We look forward to fulfilling your future requirements.

Sincerely,
FMH Conveyors

Table of Contents

Thank You	2
Warranty Statement, Service Instructions and Safety Information	4
General Operation	5
Accumulation Full Interface Signal	5
Installation Instructions and Maintenance Schedule	6
DC Motor Brush Maintenance	7
Accumulation Troubleshooting Guide	8-10
Circuit Component Layout	11
Leg Mounted Photo-Sensors	
Input Zone Layout and Parts List	12-13
Middle Zone Layout and Parts List	14-15
Last Zone Layout and Parts List	16-17
Read-Between-Roller Mounted Photo-Sensors	
Input Zone Layout and Parts List	18-19
Middle Zone Layout and Parts List	20-21
Last Zone Layout and Parts List	22-23
Power Supply Connection Diagram	25
Zone Connection Diagram	26
Interface Connection Diagram	27
Receiving Interface Connection Diagram	28
Recommended Spare Parts List	29
Addendum A: Order Specific Manuals, Inserts and Drawings (as required)	

Warranty Statement

Your FMH Conveyor is protected by our premier warranty. F M H Conveyors will replace, free of charge, parts that are damaged during the course of normal operation due to material or workmanship defects. This warranty extends for a period of two (2) years on all mechanical components and one (1) year on all electrical components (measured from the date you took possession of your conveyor.)

This warranty does not cover damage due to accident, misuse, abuse and negligence. This warranty does not cover damage due to improper operation or maintenance, connection to improper voltage supply, or attempted repair/modification by anyone other than an authorized FMH Conveyors service personnel.

For specific warranty information or assistance, please contact your FMH Conveyors sales representative at 800-327-9209.

Service Instructions

If your FMH Conveyor needs service or replacement parts, please contact your distributor or our factory toll free at **800-327-9209**.

Safety Information

- Move conveyor only by grasping the handles located on each side at both ends of the conveyor.
- When expanding or compacting your conveyor, keep hands, clothing and other items clear of the sidebars.
- Do not exceed the conveyor load capacity, as it may result in possible operator injury or conveyor damage.
- Avoid wearing excessively loose clothing when working with moving equipment.
- Keep long hair pulled up to prevent it from becoming caught in moving parts.
- Broken or worn parts must be immediately replaced.
- FMH Conveyors must only be serviced by properly trained and qualified technicians.
- Conveyor's power cord must be connected to a grounded receptacle that is protected by an over current device rated at no more than 15 amps, unless otherwise specified.
- Never service a conveyor with the power applied. Always disconnect power before servicing equipment.
- Never operate conveyor with an electrical enclosure open.

General Operation

The BestFlex Power Conveyor is a flexible, expandable powered conveyor that operates from a standard 115VAC grounded outlet. **(Unless otherwise noted.)**

The accumulation option allows zero pressure accumulation of packages in individual zones along the conveyor. Packages are detected by photoelectric sensors located at the end of each zone. When no packages are on the conveyor, all zones will run. The first package placed on the conveyor will travel to the last zone on the discharge end of the conveyor and stop when it breaks that zone's photoeye beam. The remaining zones continue to run. The next package placed on the conveyor will stop at the next-to-last zone. Packages will continue to accumulate the length of the conveyor. This allows full utilization of the conveyor without letting packages become damaged from over crowding or "bunching up" on the conveyor.

When the package in the discharge end zone is removed from the conveyor, all zones will start and the packages will again "accumulate" toward the discharge end of the conveyor.

The accumulation conveyor comes with photoelectric sensors set in two configurations. Note that the configuration is determined by the customer at the time of the order.

One configuration is with the photo-eyes mounted on the leg above and outside the conveyor bed. This configuration is known as ***Leg Mount Optics***.

The second configuration is with the photo-eyes mounted slightly below and in the conveyor bed, at the leg locations. This configuration is known as ***Read Between Roller Optics***.

Accumulation Full Interface Signal

Two sets of dry contacts, one normally open and one normally closed, are provided to give an interface signal from the BestFlex conveyor to a host control system. The normally open contacts will be closed anytime one or more zones of the BestFlex Accumulation conveyor are running. A terminal block for these contacts is provided on the power supply board located in the larger enclosure at the end of the conveyor. (Refer to the Power Supply Connection Diagram.) This terminal block is labeled "Extra Contact". The individual terminals are labeled "NO" (normally open), "COM" (common), "NC" (normally closed) and "GRD" (ground). These contacts are rated up to 10A/250VAC or 10A/30VDC.

CAUTION: *Always unplug the 115VAC power cord before working on the unit or opening any electrical enclosures. Never operate the conveyor with the enclosures open.*

Installation Instructions

- 1) Unpack the BestFlex Power Conveyor and inspect for possible damage that may have occurred during shipping. Pay particular attention to the wiring to ensure that no wires are pulled loose or damaged in any way. If you find any damage, contact the factory before applying power to the conveyor.
- 2) Make sure all Start/Stop push-buttons are in the STOP position (there will be one at each end of the conveyor.)
- 3) Roll the unit into position. If applicable, use the connect hooks to attach the Best/Flex to a rigid conveyor.
- 4) Plug the power cord into a 115VAC grounded receptacle.
- 5) Release **all** Start/Stop push-buttons (a single Start/Stop push-button that has the Stop button depressed will prevent the conveyor from running.) There may be a stand-alone motor controller mounted near the middle of the unit. If this is the case, make sure its switch is in the "On" position. **All** switches must be in the "Start", "Run", or "On" position.
- 6) Adjust the speed of the conveyor to suit the application. Adjust the speed by turning the potentiometer. Depending on the unit configuration, the potentiometer will either be located on the main power enclosure or the motor controller mounted near the middle of the conveyor.
- 7) Begin placing packages on the conveyor. They will travel to the last available zone and stop until packages are removed from the discharge end.

Maintenance Schedule

The BestFlex Power Conveyor is virtually maintenance free. We do recommend that you regularly inspect the unit to ensure proper operation of mechanical and safety systems.

DAILY:

- Keep the conveyor clean and free of debris, dirt and grease accumulation.
- Periodically lubricate all slotted components with a lightweight lubricant to ensure smooth and easy operation.
- Inspect wires and cables for damage. If damage to wires or cables is found, disconnect the power cord immediately and do not operate unit until proper repair is completed.
- Inspect belts for wear. Replace excessively worn belts.
- Inspect sidebar nuts and bolts for looseness or missing parts. Tighten or replace as needed.
- Make sure reflectors and photoeyes are clean, unobstructed and properly aligned.
- Verify all Start/Stop push-buttons operate properly.

DC Motor Brush Maintenance

All motors used to power the conveying surfaces of the BestFlex Powered Conveyors are DC permanent magnet motors. These motors have a pair of serviceable brushes that wear with use. Brush life is affected by the speed of the motor, the loads being conveyed, the number of start-stop cycles and other factors. Therefore, brush life will vary from application to application.

To ensure long motor life, brush inspection should be included in the normal maintenance schedule. Brushes should be periodically removed, visually inspected and measured.

The brushes are accessed by removing the two caps on the end of the motor opposite of the gearbox (see photos below). Use a proper fitting flat head screwdriver to avoid damaging the cap. With the cap removed, the brush may be removed from its holder by pulling on the spring. Visually inspect the brushes for chips or grooves. The shunt wire should not be frayed or broken. The brush should be replaced if it measures 0.125 inches or less as shown in Figure 1. Possible armature damage could result from running the brushes beyond this wear point.

When being installed, the brush should slide freely into the holder. The brass contact connected to the top of the spring should be installed so its tabs are aligned with the motor shaft (see Photo 2). One tab should be facing the rear of the motor and the other tab toward the front. The tabs should go easily into the brush holder. Do not over tighten the plastic cap that holds the brush in place.



Photo 1: Typical Brush Location



Photo 2

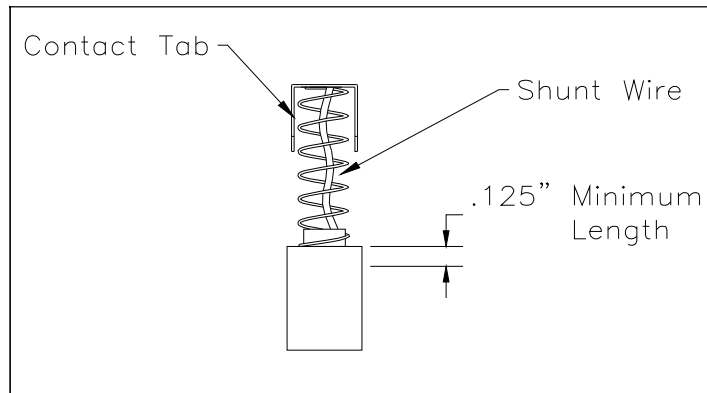

Figure 1

Accumulation Troubleshooting Guide

To use this guide, find the heading that best fits your conveyor's condition and check the numbered items in the order they appear. *It is important to proceed in the order given since it is assumed at each item that all preceding items under that heading have passed inspection.*

CAUTION: *Electrical systems should only be serviced by qualified personnel. Refer to and observe all local codes and OSHA guidelines for LOCKOUT/TAGOUT procedures. Make sure all power has been disconnected before opening any enclosure. Keep hands and tools away from electrical circuits when power is applied. 115VAC is present even when the conveyor is stopped by the STOP switch. The only way to guard against electrical shock is to unplug the conveyor from its AC power source before servicing.*

Diagnostic LEDs

To aid in troubleshooting, there are a number of LEDs mounted on the power supply printed circuit board (PCB) in the larger enclosure on the first leg of the system and on each accumulation PCB in the smaller enclosures located at each motor. These LEDs are shown on the system wire connection diagrams and their meanings are listed here.

Power Supply Board LEDs and Neon Lamp:

RED	On when STOP button is pushed and RELAY1 is off.
GREEN	On when 17VDC is present through the DC fuse.
LARGE AMBER	On when the photoeye connected to the power supply is blocked.
SMALL AMBER	On when RELAY2 is energized.
NEON LAMP	On when RELAY1 is energized and AC power is supplied to the DC controller.

Accumulation Board LEDs:

RED	On when that zone is stopped and stopped signal is sent to adjacent zones.
AMBER	On when the photoeye used for forward accumulation is blocked.
GREEN	On when the photoeye used for reverse accumulation is blocked.

NO MOTOR RUNS:

1) Check AC power coming into conveyor.

- a) Make sure the unit is plugged into a hot 115VAC outlet.
- b) Check the circuit breaker mounted in the side of the power supply enclosure. If button is out an overload has occurred. The fault causing this condition must be cleared before continuing. Once the fault is corrected, reset the breaker by pushing it in.
- c) **For Leg Mounted Optics**, if AC power is present, at least one LED on top of each photo eye will be on since the DC voltage supplying the photoeyes is derived from the AC power.
- d) AC power can be verified with an appropriate voltage meter across the L1 and E-Stop terminals on the power supply board.

Accumulation Troubleshooting Guide (cont.)

2) Check DC control voltage.

- a) Check that the Green LED on the power supply is on. If LED is off and AC voltage is present, check the ¼ amp and 2 amp fuses on the power supply board. If a fuse is blown, repair any electrical shorts or overload conditions before continuing. If fuses are not blown and the Green LED is not on, the power supply board has failed.
- b) If the Green LED is on, check for DC voltage at accumulation zones by blocking a photoeye for that zone. (For RBR photoeyes, an LED should light indicating the PE is blocked. For Leg-mounted optics, blocking the photoeye should cause the combination of illuminated LEDs should change indicating the optic is blocked.) The Amber LED on the accumulation board should be lit when that zone's photoeye is blocked. If this LED is not on, make sure all communication cables are plugged in. Check the communication cable between power supply board and first zone accumulation board.

3) Check for AC power coming into the DC motor controller.

- a) The neon lamp on the power supply board should be on whenever AC power is supplied to the DC controller. If this lamp is off and the Red LED on the power supply board is also off, check the 15 amp fuse on the power supply board that powers the DC controller. If this fuse is good, the relay on the power supply board has failed.
- b) If the Red LED is on, check to be sure all STOP pushbuttons have been released.
- c) Check the AC fuse on the DC motor controller.
- d) AC power can be verified with a volt meter at the DC controller.

4) Check for DC power on the output side of the DC motor controller.

- a) If the unit has a DC Motor Controller mounted near the center of the unit, make sure the forward/reverse switch is not in the middle position and make sure the speed control is not turned down to "zero."
- b) Check the DC fuse on the DC controller. (This is the ceramic fuse.) Either remove the fuse for continuity or check for voltage between the output side of the fuse and ground. This value should be approximately 90VDC.
- c) If the fuse is blown, the cause could be either a shorted motor cord or a motor drawing excessive current.
- d) If the DC fuse is good, the plug-in resistor is in place, and no DC voltage is present at the output of the DC motor controller, the controller has failed.

Accumulation Troubleshooting Guide (cont.)

ONE OR MORE ZONES WILL NOT RUN:

- 1) **If it's an end zone, check the zone's photoeye for alignment and proper functioning.**
 - a) **For Leg-mounted Optics**, the photoeye's Green LED will be on if its beam is blocked or the eye is not aligned with reflector. If the Green LED does not come on when the beam is broken, the photoeye is defective. **For RBR Optics**, an LED on the optic should be lit when the optic is blocked; if this is not the case, the RBR optic may be defective.
- 2) **Check accumulation board for control voltage.**
 - a) Observe photoeye's LEDs (**leg-mounted optics only**). They are powered from the accumulation's control voltage. If none are on, the photoeye may not have power. Control voltage is supplied to each accumulation board by the communication cable connected to the PREVIOUS modular connector. Check cable for broken wires or defective connectors.
 - b) Block that zone's photoeye. The Amber LED on the accumulation board should come on when the photoeye's beam is broken.
- 3) **Check for DC voltage at the motor cable's connector on the accumulation board.**
 - a) If no voltage is present, check the fuse on the accumulation board. If the fuse is blown, check for shorts in the motor cable and in the motor and then replace the fuse.
 - b) If no voltage is present and the fuse is not blown indicating a short or overload, the accumulation board is bad.
 - c) If voltage is present at the motor cable's connector, the motor or its cable is defective.

ONE PHOTOEYE STOPS TWO OR MORE ZONES:

- 1) **Check alignment of photoeyes in zones that stop when the next zone's photoeye is blocked.**
 - a) **With Leg-mounted optics**, if a zone's photoeye is not properly aligned with its reflector and the next zone's eye is blocked, both zones will operate as one. The Green LED on the top of the photoeye should only be lit when the photoeye is blocked. It will not be on when the photoeye is properly lined up with its reflector. When a photo eye's beam is not being reflected back to the photoeye the accumulation board's Amber LED will be lit. If the optics are properly aligned and one photoeye stop its zone as well as the previous zone then the accumulation board in the previous zone is probably defective.
 - b) **With RBR Optics**, if a zone's photoeyes are controlling there own zone plus the previous zone, check the optics in the previous zone to make sure one or more optics are not picking up a false signal. If no false signals are being detected, the accumulation board of the previous zone is probably defective

ZONE WILL NOT SHUT OFF WHEN PHOTOEYE IS BLOCKED AND NEXT ZONE IS OFF:

- 1) **Check photoeye for proper function.**
 - a) Make sure the accumulation's Amber LED is on when the photoeye is blocked. If it does not come on, check the connections from the photoeye cable at the board's connector. The photoeye could also be defective.

Circuit Component Layout

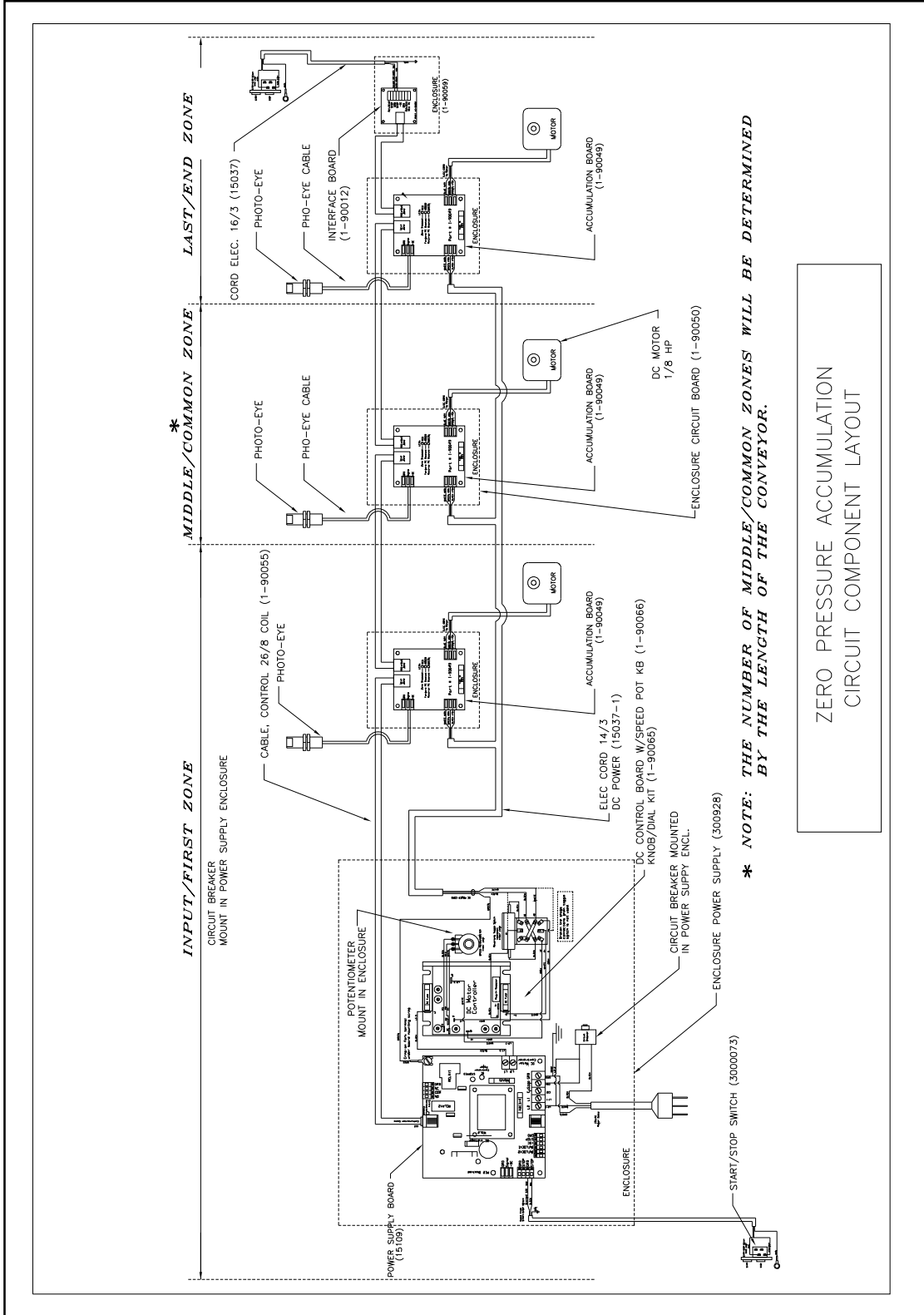

Input Zone Layout: Leg Mount Accumulation

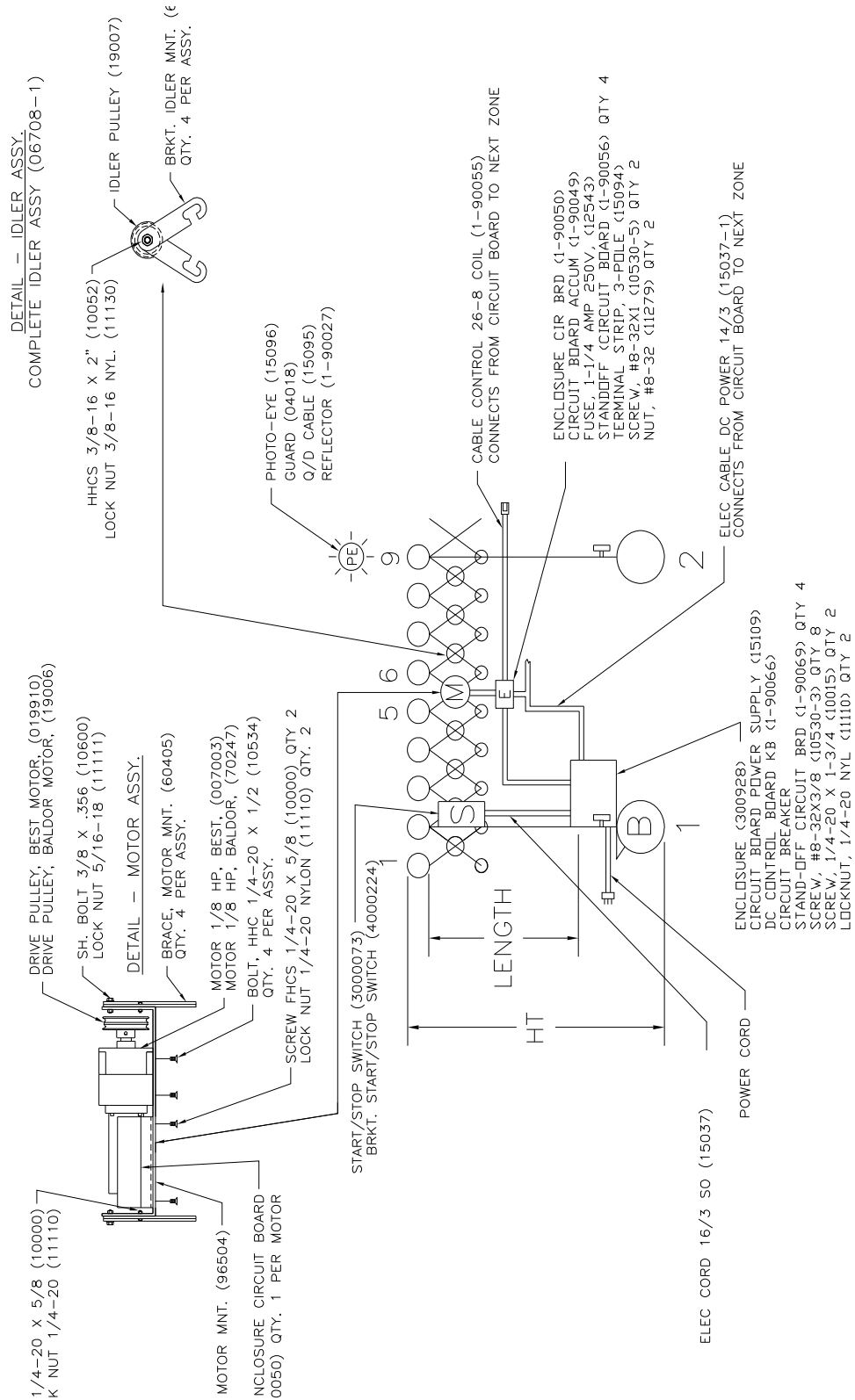

FMH Conveyors Operator's Manual
BestFlex BFP 1.5 and BFP 1.9

Input Zone Parts List: Leg Mount Accumulation

1-90049	1	Circuit Board, 2-Way Accum.	11111	As Required	Locknut, Nylon, 5/16
15109	1	Circuit Board, Power Supply	12185	As Required	Spacer, 3/4 OD x 13/32 ID x 0.20
1-90056	4	Stand off, Plastic	12187	As Required	Washer, Nylon, 1" OD
1-90069	4	Spacer, 1/4 HEX x 3/4 LG	60081-PR	As Required	Leg Mount Bracket, 5" or
15037-1	6 Ft.	Electrical Cord, 14/3 SJ 300V	60379-PR	As Required	Leg Mount Bracket, 4" or
1-90055	1	Cable Control 26/8	60375	As Required	Leg Mount Bracket, 3-1/2" or
1-90050	1	Enclosure Assembly, Circuit Board	60295-PR	As Required	Leg Mount Bracket, 3"
300928	1	Enclosure, Power Supply	60463-5	As Required	Roller Mount Bracket, 5" or
1-90066	1	Control Board with Speed POT	60463-4	As Required	Roller Mount Bracket, 4" or
1-90065	1	Knob/Dial Kit, KB Control	60463-35	As Required	Roller Mount Bracket, 3-1/2" or
1-90067	1	Circuit Breaker, 15 Amp Service or	60463-3	As Required	Roller Mount Bracket, 3"
1-90076	1	Circuit Breaker, 20 Amp Service or	50098-ZZ	As Required	Roller 1.5 x ZZ* (SEE NOTE BELOW) or
1-90068	1	Circuit Breaker, 30 Amp Service	50099-ZZ	As Required	Roller 1.9 x ZZ* (SEE NOTE BELOW)
10530-2	4	RHMS #10-24 x 3/4	95037-ZZ	As Required	Axle 12mm x ZZ* Length, 5/16 THD
11999	4	Washer, Flat, 3/16"	10024	As Required	Screw, HHC 5/16-18 x 1/2
12120	4	Washer, Lock, 3/16"	007003	1	Motor, 180V, DC 1/8 HP (0-120 FPM) or
11279-1	4	Nut, HEX #10-32	007003	1	Motor, 90V, DC 1/8 HP (0-200 FPM)
15096	1	Photo-Eye Sensor AB NPN	96504	1	Bracket Motor Mount
15095	1	Cable Q/D Brad Harrison	60405	4	Brace Motor Mount
1-90027	2	Reflector	10000	2	Screw, HHC 1/4-20 x 5/8
04018	2	Photo-Eye Mount Bracket with Guard	11110	2	Locknut, 1/4-20 Nylon
60900	2	Photo-Eye Mount Bracket AB	10052	6	Screw, HHC 3/8-16 x 2
1-90019	3	Strain Relief, .250 Cable	11130	6	Locknut, 3/8-16 Nylon
12000	4	Washer, Flat, 1/4"	019910	1	Pulley, Drive, Double Groove
11110	6	Locknut, Nylon, 1/4"	19007	As Required	Pulley, Idler, Double Groove
3000073	1	Start/Stop Motor Control	60406	As Required	Idler Mount Bracket
15037	3 Ft.	Electrical Cord, 16/3	12466	2	Drive Belt
15019	1	Plug/Cord M 12/3 300V 3' or	12467	As Required	Idler Belt
15024-30	1	Male Power Plug, 30 Amp <i>plus</i>	1-90049-S	1	Accumulation Schematic
15037-7	3 Ft.	Electrical Cord, 10/3 (30-AMP UNIT)	10015	2	Screw, HHC 1/4-20 x 1-3/4"
1-90070	1	Strain Relief, 7P2	10534	4	Bolt, HHC 1/4-20 x 1/2"
1-90071	3	Strain Relief, #MP30-1	15025	25	Cable Tie, 3/8L, 3/16W
1-90072	2	Strain Relief, MP4K1	15030-3	8	Screw, #8-32X3/8 RHM
15012-1	3	Strain Relief, 16/3 Wire	15045-15	1	Fuse, 15 Amp, 250V Ceramic
15015	7	Terminal Fork #10, Stud 16-14GAB	15097	4	1/2" Cable Clamp Hanger
60492	As Required	Sidebar, BFP15 or	15098	8	Nylon Axle Clamp
60507	As Required	Sidebar, BFP19	15109-S	1	Power Supply Schematic
10600	As Required	Sidebar Bolt, 3/8 x 3/8, 5/16 THD	60440	1	Strap, Enclosure Support
10620	As Required	Sidebar Bolt, 3/8 x 0.70, 5/16 THD	15030-5	2	Screw, #8-32 X 1
10624	As Required	Sidebar Bolt, 3/8 x 1.10, 5/16 THD	11279	2	Nut, #8-32
15094	1	Terminal Strip, 3-Pole			

Note: ZZ is determined by the unit width and will either be 18, 24, or 30. So, for a BFP1.5 conveyor with that is 24-inches wide, your roller number will be 50098-24 and your axle number will be 95037-24.

Middle Zone Layout: Leg Mount Accumulation

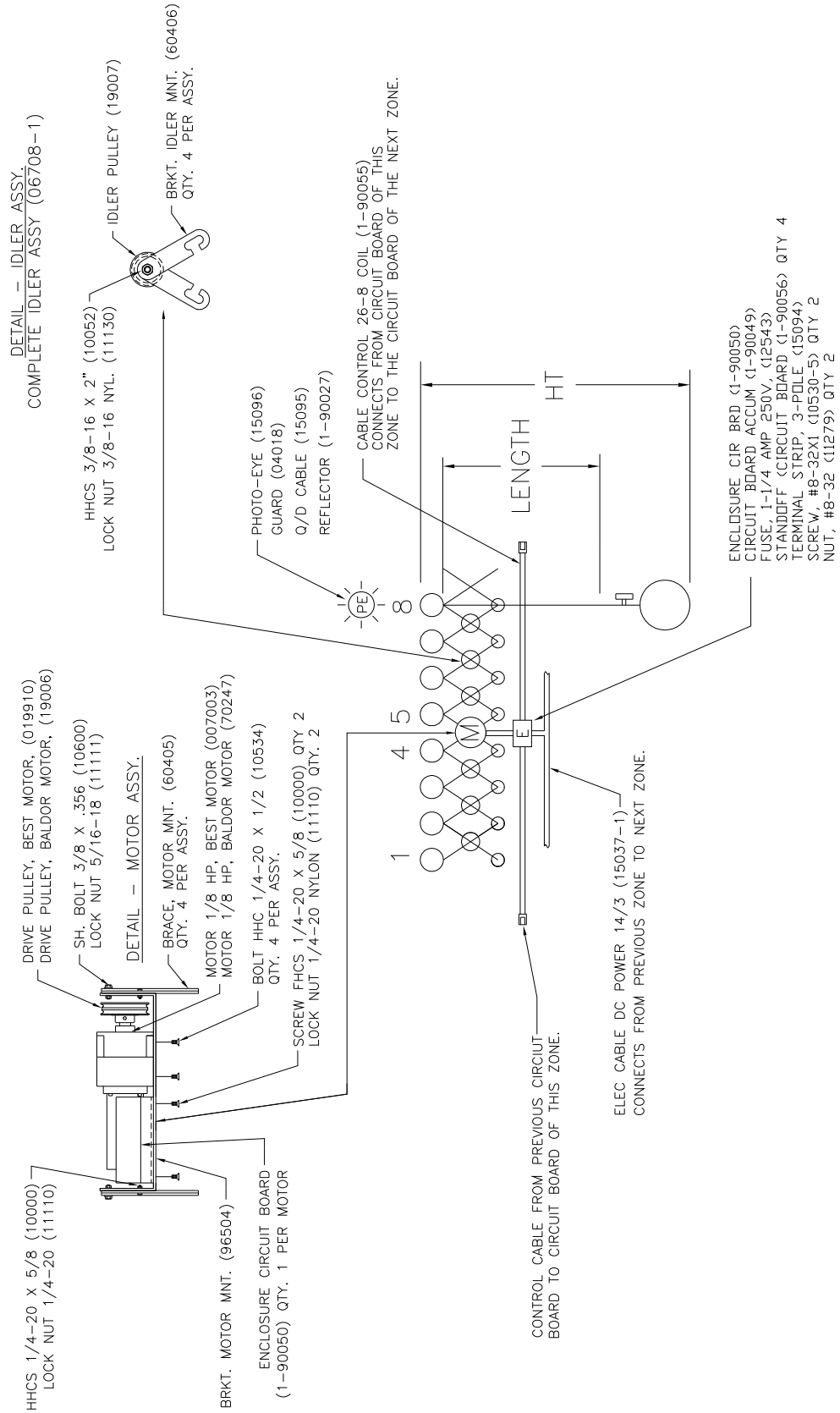

FMH Conveyors Operator's Manual

BestFlex BFP 1.5 and BFP 1.9

Middle Zone Parts List: Leg Mount Accumulation

1-90049	1	Circuit Board, 2-Way Accum.	15094	1	Terminal Strip, 3-Pole
1-90056	4	Stand off, Plastic	60463-5	As Required	Roller Mount Bracket, 5" or
15037-1	6 Ft.	Electrical Cord, 14/3 SJ 300V	60463-4	As Required	Roller Mount Bracket, 4" or
1-90055	1	Cable Control 26/8	60463-35	As Required	Roller Mount Bracket, 3-1/2" or
1-90050	1	Enclosure Assembly, Circuit Board	60463-3	As Required	Roller Mount Bracket, 3"
1-90081	1	Enclosure Cover	50098-ZZ	As Required	Roller 1.5 xZZ* (SEE NOTE BELOW) or
1-90152	1	Thumb Screw, #8-32	50099-ZZ	As Required	Roller 1.9 xZZ* (SEE NOTE BELOW)
1-90153	1	Nut, U-Clip, #8-32	95037-ZZ	As Required	Axle 12mm xZZ* Length, 5/16 THD
15096	1	Photo-Eye Sensor AB NPN	10024	As Required	Screw, HHC 5/16-18 x1/2
15095	1	Cable Q/D Brad Harrison	007003	1	Motor, 180V, DC 1/8 HP (0-120 FPM) or
1-90027	2	Reflector	007003	1	Motor, 90V, DC 1/8 HP (0-200 FPM)
04018	2	Photo-Eye Mount Bracket with Guard	96504	1	Bracket Motor Mount
60900	2	Photo-Eye Mount Bracket AB	60405	4	Brace Motor Mount
12000	2	Washer, Flat, 1/4"	10000	2	Screw, HHC 1/4-20 x5/8
11110	2	Locknut, Nylon, 1/4"	11110	2	Locknut, 1/4-20 Nylon
1-90070	1	Strain Relief, 7P2	10052	6	Screw, HHC 3/8-16 x2
1-90071	3	Strain Relief, #MP30-1	11130	6	Locknut, 3/8-16 Nylon
1-90072	2	Strain Relief, MP4K1	019910	1	Pulley, Drive, Double Groove
15012-1	3	Strain Relief, 16/3 Wire	19007	As Required	Pulley, Idler, Double Groove
15015	7	Terminal Fork #10, Stud 16-14GAB	60406	As Required	Idler Mount Bracket
60492	As Required	Sidebar, BFP15 or	12466	2	Drive Belt
60507	As Required	Sidebar, BFP19	12467	As Required	Idler Belt
10600	As Required	Sidebar Bolt, 3/8 x3/8, 5/16 THD	1-90049-S	1	Accumulation Schematic
10620	As Required	Sidebar Bolt, 3/8 x0.70, 5/16 THD	10015	2	Screw, HHC 1/4-20 x1-3/4"
10624	As Required	Sidebar Bolt, 3/8 x1.10, 5/16 THD	10534	4	Bolt, HHC 1/4-20 x1/2"
11111	As Required	Locknut, Nylon, 5/16	15025	25	Cable Tie, 3/8L, 3/16W
12185	As Required	Spacer, 3/4 OD x13/32 ID x0.20	15030-3	8	Screw, #8-32X3/8 RHM
12187	As Required	Washer, Nylon, 1" OD	15097	4	1/2" Cable Clamp Hanger
60081-PR	As Required	Leg Mount Bracket, 5" or	15098	8	Nylon Axle Clamp
60379-PR	As Required	Leg Mount Bracket, 4" or	15030-5	2	Screw, #8-32 X1
60375	As Required	Leg Mount Bracket, 3-1/2" or	11279	2	Nut, #8-32
60295-PR	As Required	Leg Mount Bracket, 3"			

Note: ZZ is determined by the unit width and will either be 18, 24, or 30. So, for a BFP1.5 conveyor with that is 24-inches wide, your roller number will be 50098-24 and your axle number will be 95037-24.

Last Zone Layout: Leg Mount Accumulation

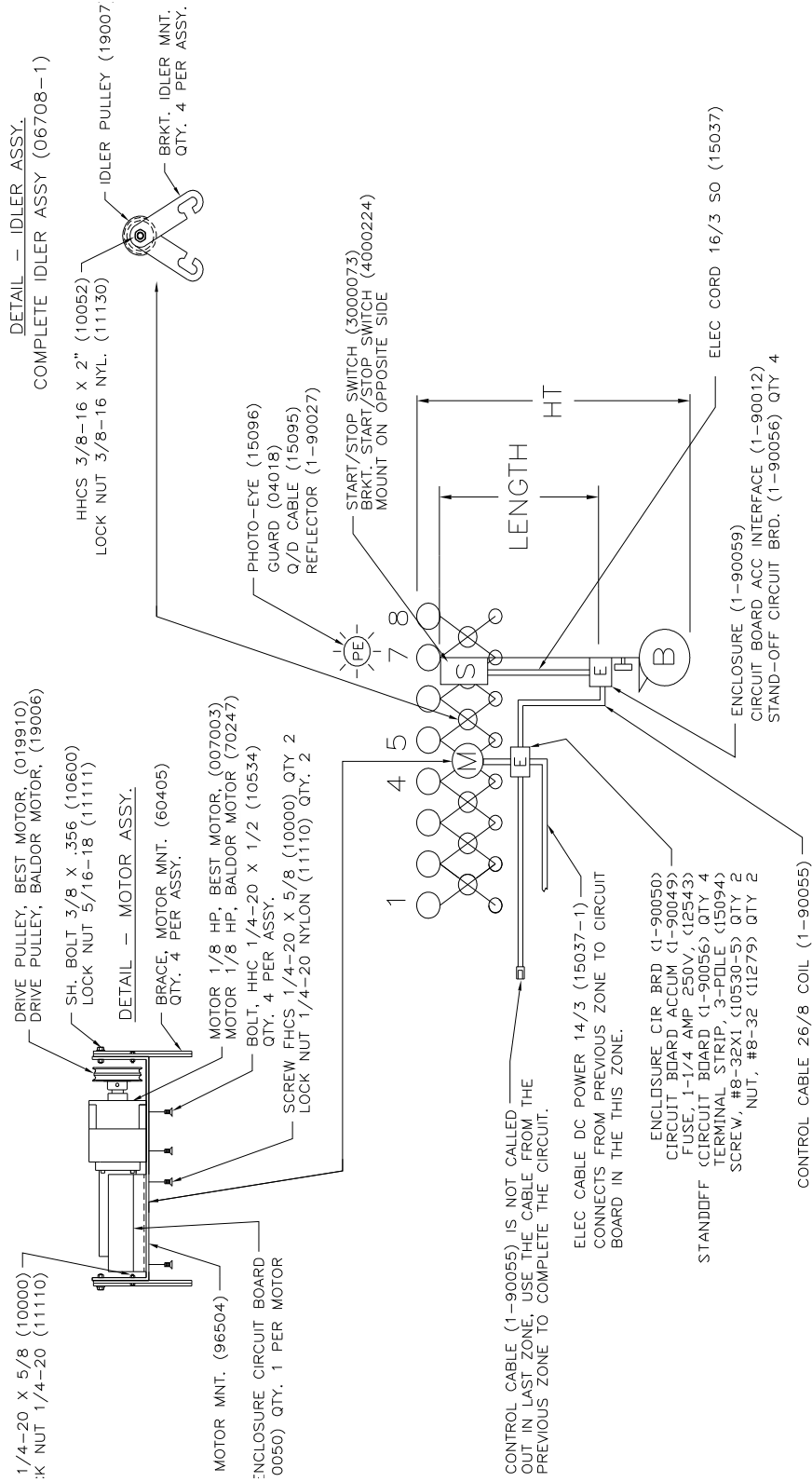

FMH Conveyors Operator's Manual
BestFlex BFP 1.5 and BFP 1.9

Last Zone Parts List: Leg Mount Accumulation

1-90049	1	Circuit Board, 2-Way Accum.	60081-PR	As Required	Leg Mount Bracket, 5" or
1-90012	1	Interface Board	60379-PR	As Required	Leg Mount Bracket, 4" or
1-90069	4	Spacer, 1/4 HEX x 3/4 Leg	60375	As Required	Leg Mount Bracket, 3-1/2" or
15037-1	6 Ft.	Electrical Cord, 14/3 SJ 300V	60295-PR	As Required	Leg Mount Bracket, 3"
1-90055	1	Cable Control 26/8	60463-5	As Required	Roller Mount Bracket, 5" or
1-90059	1	Enclosure	60463-4	As Required	Roller Mount Bracket, 4" or
1-90056	4	Stand off, Plastic	60463-35	As Required	Roller Mount Bracket, 3-1/2" or
1-90050	1	Enclosure Assembly, Circuit Board	60463-3	As Required	Roller Mount Bracket, 3"
15096	1	Photo-Eye Sensor AB NPN	50098-ZZ	As Required	Roller 1.5 xZZ* (SEE NOTE BELOW) or
15095	1	Cable Q/D Brad Harrison	50099-ZZ	As Required	Roller 1.9 xZZ* (SEE NOTE BELOW)
1-90027	1	Reflector	95037-ZZ	As Required	Axle 12mm xZZ* Length, 5/16 THD
04018	2	Photo-Eye Mount Bracket with Guard	10024	As Required	Screw, HHC 5/16-18 x 1/2
60900	2	Photo-Eye Mount Bracket AB	007003	1	Motor, 180V, DC 1/8 HP (0-120 FPM) or
1-90019	3	Strain Relief, .250 Cable	007003	1	Motor, 90V, DC 1/8 HP (0-200 FPM)
12000	4	Washer, Flat, 1/4"	96504	1	Bracket Motor Mount
11110	6	Locknut, Nylon, 1/4"	60405	4	Brace Motor Mount
3000073	1	Start/Stop Motor Control	10000	2	Screw, HHC 1/4-20 x 5/8
15037	3 Ft.	Electrical Cord, 16/3 SO	11110	2	Locknut, 1/4-20 Nylon
1-90070	1	Strain Relief, 7P2	10052	6	Screw, HHC 3/8-16 x 2
1-90071	3	Strain Relief, #MP30-1	11130	6	Locknut, 3/8-16 Nylon
1-90072	2	Strain Relief, MP4K1	019910	1	Pulley, Drive, Double Groove
15012-1	3	Strain Relief, 16/3 Wire	19007	As Required	Pulley, Idler, Double Groove
15015	7	Terminal Fork #10, Stud 16-14GAB	60406	As Required	Idler Mount Bracket
60492	As Required	Sidebar, BFP15 or	12466	2	Drive Belt
60507	As Required	Sidebar, BFP19	12467	As Required	Idler Belt
10600	As Required	Sidebar Bolt, 3/8 x 3/8, 5/16 THD	1-90049-S	1	Accumulation Schematic
10620	As Required	Sidebar Bolt, 3/8 x 0.70, 5/16 THD	10015	2	Screw, HHC 1/4-20 x 1-3/4"
10624	As Required	Sidebar Bolt, 3/8 x 1.10, 5/16 THD	10534	4	Bolt, HHC 1/4-20 x 1/2"
11111	As Required	Locknut, Nylon, 5/16	15025	25	Cable Tie, 3/8L, 3/16W
12185	As Required	Spacer, 3/4 OD x 13/32 ID x 0.20	15030-3	8	Screw, #8-32X3/8 RHM
12187	As Required	Washer, Nylon, 1" OD	15097	4	1/2" Cable Clamp Hanger
15094	1	Terminal Strip, 3-Pole	15098	8	Nylon Axle Clamp
15030-5	2	Screw, #8-32 X 1			
11279	2	Nut, #8-32			

Note: ZZ is determined by the unit width and will either be 18, 24, or 30. So, for a BFP1.5 conveyor with that is 24-inches wide, your roller number will be 50098-24 and your axle number will be 95037-24.

Input Zone Layout: Read-Between-Roller Accumulation

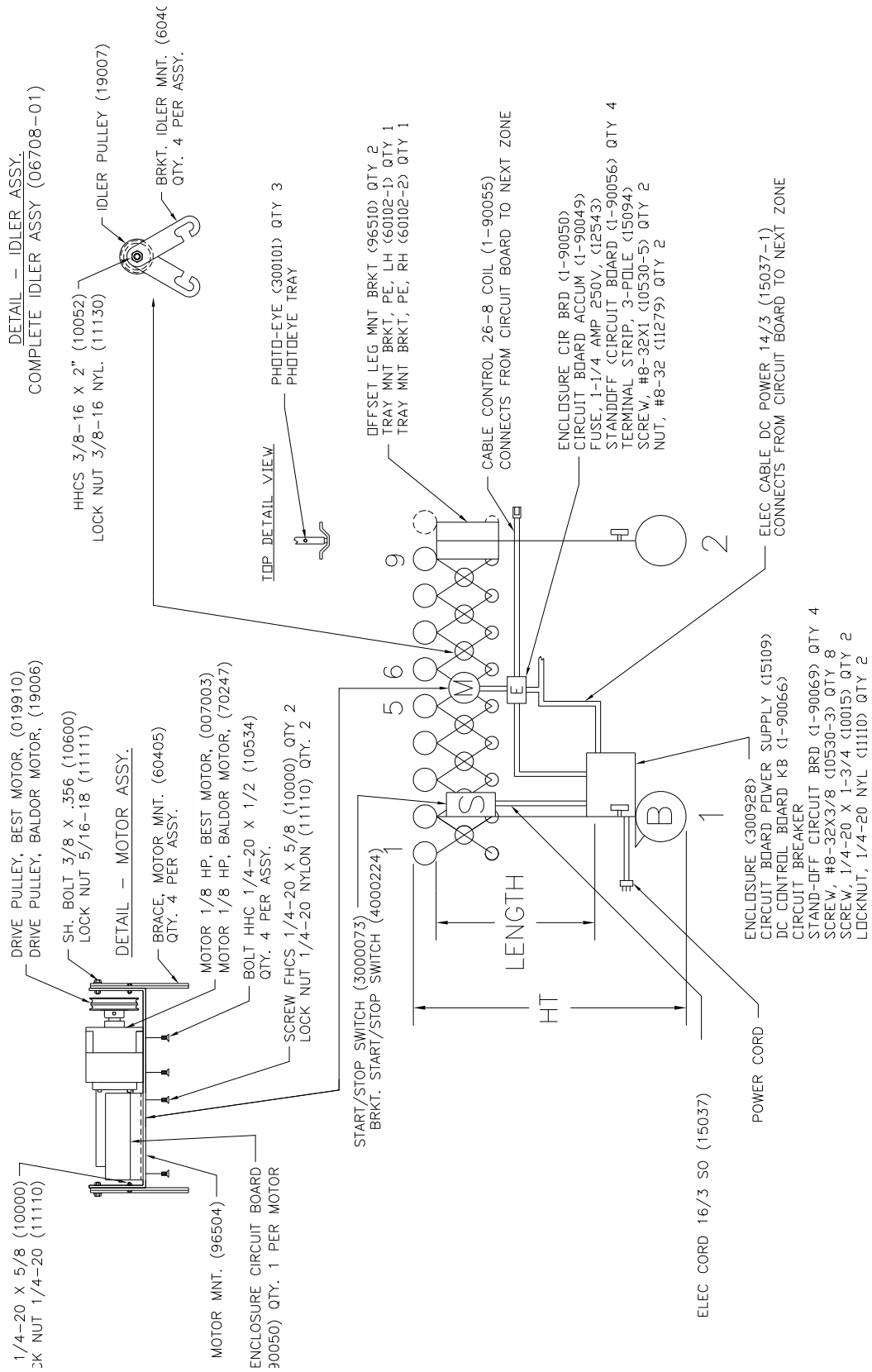

FMH Conveyors Operator's Manual
BestFlex BFP 1.5 and BFP 1.9

Input Zone Parts List: Read-Between-Roller Accumulation

1-90049	1	Circuit Board, 2-Way Accum.	15094	1	Terminal Strip, 3-Pole
15109	1	Circuit Board, Power Supply	11111	As Required	Locknut, Nylon, 5/16
1-90056	4	Stand off, Plastic	12185	As Required	Spacer, 3/4 OD x13/32 ID x0.20
1-90069	4	Spacer, 1/4 HEX x3/4 LG	12187	As Required	Washer, Nylon, 1" OD
15037-1	6 Ft.	Electrical Cord, 14/3 SJ 300V	60081-PR	As Required	Leg Mount Bracket, 5" or
1-90055	1	Cable Control 26/8	60379-PR	As Required	Leg Mount Bracket, 4" or
1-90050	1	Enclosure Assembly, Circuit Board	60375	As Required	Leg Mount Bracket, 3-1/2" or
300928	1	Enclosure, Power Supply	60295-PR	As Required	Leg Mount Bracket, 3"
1-90066	1	Control Board with Speed POT	60463-5	As Required	Roller Mount Bracket, 5" or
1-90065	1	Knob/Dial Kit, KB Control	60463-4	As Required	Roller Mount Bracket, 4" or
1-90067	1	Circuit Breaker, 15 Amp Service or	60463-35	As Required	Roller Mount Bracket, 3-1/2" or
1-90076	1	Circuit Breaker, 20 Amp Service or	60463-3	As Required	Roller Mount Bracket, 3"
1-90068	1	Circuit Breaker, 30 Amp Service	50098-ZZ	As Required	Roller 1.5 x ZZ* (SEE NOTE BELOW) or
10530-2	4	RHMS #10-24 x3/4	50099-ZZ	As Required	Roller 1.9 x ZZ* (SEE NOTE BELOW)
11999	4	Washer, Flat, 3/16"	95037-ZZ	As Required	Axle 12mm x ZZ* Length, 5/16 THD
12120	4	Washer, Lock, 3/16"	10024	As Required	Screw, HHC 5/16-18 x1/2
11279-1	4	Nut, HEX#10-32	007003	1	Motor, 180V, DC 1/8 HP (0-120 FPM) or
300101	3	Photo-Eye Sensor Diffuse	007003	1	Motor, 90V, DC 1/8 HP (0-200 FPM)
60102-1	1	Tray Mount Bracket, PE, LH	96504	1	Bracket Motor Mount
60102-2	1	Tray Mount Bracket, PE, RH	60405	4	Brace Motor Mount
96510	2	Offset Leg Mount Bracket	10000	2	Screw, HHC 1/4-20 x5/8
60101-18	1	Photo-Eye Mount Tray, 18" or	11110	2	Locknut, 1/4-20 Nylon
60101	1	Photo-Eye Mount Tray, 24" or	10052	6	Screw, HHC 3/8-16 x2
60101-30	1	Photo-Eye Mount Tray, 30"	11130	6	Locknut, 3/8-16 Nylon
1-90019	3	Strain Relief, .250 Cable	019910	1	Pulley, Drive, Double Groove
12000	4	Washer, Flat, 1/4"	19007	As Required	Pulley, Idler, Double Groove
11110	6	Locknut, Nylon, 1/4"	60406	As Required	Idler Mount Bracket
3000073	1	Start/Stop Motor Control	12466	2	Drive Belt
15037	3 Ft.	Electrical Cord, 16/2 SO	12467	As Required	Idler Belt
15019	1	Plug/Cord M12/3 300V 3' or	1-90049-S	1	Accumulation Schematic
15024-30	1	Male Power Plug, 30 Amp plus	10015	2	Screw, HHC 1/4-20 x1-3/4"
15037-7	3 Ft.	Electrical Cord, 10/3 (30-AMP Only)	10534	4	Bolt, HHC 1/4-20 x1/2"
1-90070	1	Strain Relief, 7P2	15025	25	Cable Tie, 3/8L, 3/16W
1-90071	3	Strain Relief, #MP30-1	15030-3	8	Screw, #8-32X3/8 RHM
1-90072	2	Strain Relief, MP4K1	15045-15	1	Fuse, 15 Amp, 250V Ceramic
15012-1	3	Strain Relief, 16/3 Wire	15097	4	1/2" Cable Clamp Hanger
15015	7	Terminal Fork #10, Stud 16-14GAB	15098	8	Nylon Axle Clamp
60492	As Required	Sidebar, BFP15 or	15109-S	1	Power Supply Schematic
60507	As Required	Sidebar, BFP19	60440	1	Strap, Enclosure Support
10600	As Required	Sidebar Bolt, 3/8 x3/8, 5/16 THD	15030-5	2	Screw, #8-32 X1
10620	As Required	Sidebar Bolt, 3/8 x0.70, 5/16 THD	11279	2	Nut, #8-32
10624	As Required	Sidebar Bolt, 3/8 x1.10, 5/16 THD			

Note: ZZ is determined by the unit width and will either be 18, 24, or 30. So, for a BFP1.5 conveyor with that is 24-inches wide, your roller number will be 50098-24 and your axle number will be 95037-24.

Middle Zone Layout: Read-Between-Roller Accumulation

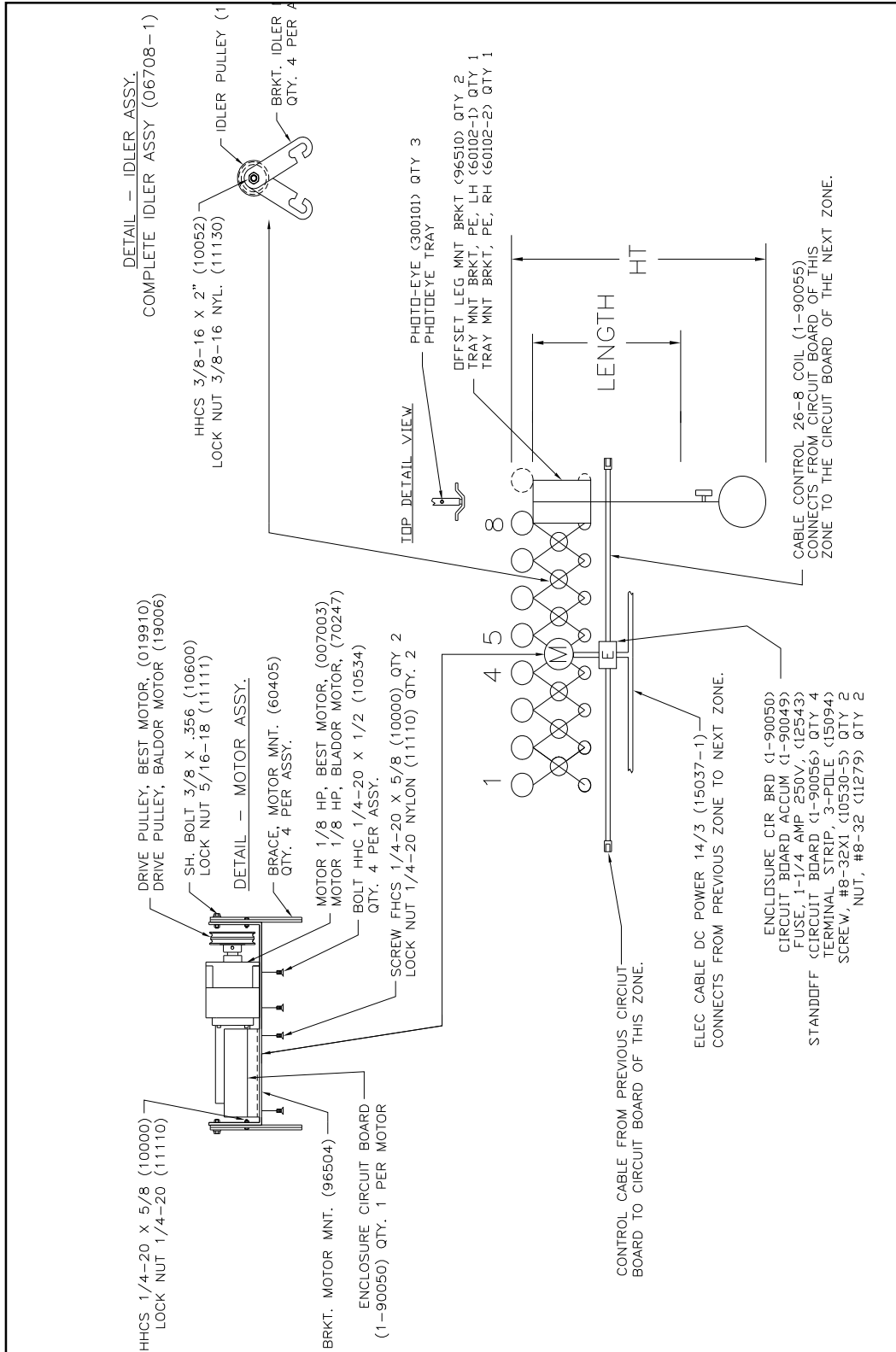

FMH Conveyors Operator's Manual
BestFlex BFP 1.5 and BFP 1.9

Middle Zone Parts List: Read-Between-Roller Accumulation

1-90049	1	Circuit Board, 2-Way Accum.	60295-PR	As Required	Leg Mount Bracket, 3"
1-90056	4	Stand off, Plastic	15094	1	Terminal Strip, 3-Pole
15037-1	6 Ft.	Electrical Cord, 14/3 SJ 300V	60463-5	As Required	Roller Mount Bracket, 5" or
1-90055	1	Cable Control 26/8	60463-4	As Required	Roller Mount Bracket, 4" or
1-90050	1	Enclosure Assembly, Circuit Board	60463-35	As Required	Roller Mount Bracket, 3-1/2" or
1-90081	1	Enclosure Cover	60463-3	As Required	Roller Mount Bracket, 3"
1-90152	1	Thumb Screw, #8-32	50098-ZZ	As Required	Roller 1.5 x ZZ* (SEE NOTE BELOW) or
1-90153	1	Nut, U-Clip, #8-32	50099-ZZ	As Required	Roller 1.9 x ZZ* (SEE NOTE BELOW)
300101	3	Photo-Eye Sensor Diffuse	95037-ZZ	As Required	Axle 12mm x ZZ* Length, 5/16 THD
60102-1	1	Tray Mount Bracket, PE, LH	10024	As Required	Screw, HHC 5/16-18 x 1/2
60102-2	1	Tray Mount Bracket, PE, RH	007003	1	Motor, 180V, DC 1/8 HP (0-120 FPM) or
96510	2	Offset Leg Mount Bracket	007003	1	Motor, 90V, DC 1/8 HP (0-200 FPM)
60101-18	1	Photo-Eye Mount Tray, 18" or	96504	1	Bracket Motor Mount
60101	1	Photo-Eye Mount Tray, 24" or	60405	4	Brace Motor Mount
60101-30	1	Photo-Eye Mount Tray, 30"	10000	2	Screw, HHC 1/4-20 x 5/8
12000	2	Washer, Flat, 1/4"	11110	2	Locknut, 1/4-20 Nylon
11110	2	Locknut, Nylon, 1/4"	10052	6	Screw, HHC 3/8-16 x 2
1-90070	1	Strain Relief, 7P2	11130	6	Locknut, 3/8-16 Nylon
1-90071	3	Strain Relief, #MP30-1	019910	1	Pulley, Drive, Double Groove
1-90072	2	Strain Relief, MP4K1	19007	As Required	Pulley, Idler, Double Groove
15012-1	3	Strain Relief, 16/3 Wire	60406	As Required	Idler Mount Bracket
15015	7	Terminal Fork #10, Stud 16-14GAB	12466	2	Drive Belt
60492	As Required	Sidebar, BFP15 or	12467	As Required	Idler Belt
60507	As Required	Sidebar, BFP19	1-90049-S	1	Accumulation Schematic
10600	As Required	Sidebar Bolt, 3/8 x 3/8, 5/16 THD	10015	2	Screw, HHC 1/4-20 x 1-3/4"
10620	As Required	Sidebar Bolt, 3/8 x 0.70, 5/16 THD	10534	4	Bolt, HHC 1/4-20 x 1/2"
10624	As Required	Sidebar Bolt, 3/8 x 1.10, 5/16 THD	15025	25	Cable Tie, 3/8L, 3/16W
11111	As Required	Locknut, Nylon, 5/16	15030-3	8	Screw, #8-32X3/8 RHM
12185	As Required	Spacer, 3/4 OD x 13/32 ID x 0.20	15097	4	1/2" Cable Clamp Hanger
12187	As Required	Washer, Nylon, 1" OD	15098	8	Nylon Axle Clamp
60081-PR	As Required	Leg Mount Bracket, 5" or	15030-5	2	Screw, #8-32 X 1
60379-PR	As Required	Leg Mount Bracket, 4" or	11279	2	Nut, #8-32
60375	As Required	Leg Mount Bracket, 3-1/2" or			

Note: ZZ is determined by the unit width and will either be 18, 24, or 30. So, for a BFP1.5 conveyor with that is 24-inches wide, your roller number will be 50098-24 and your axle number will be 95037-24.

Last Zone Layout: Read-Between-Roller Accumulation

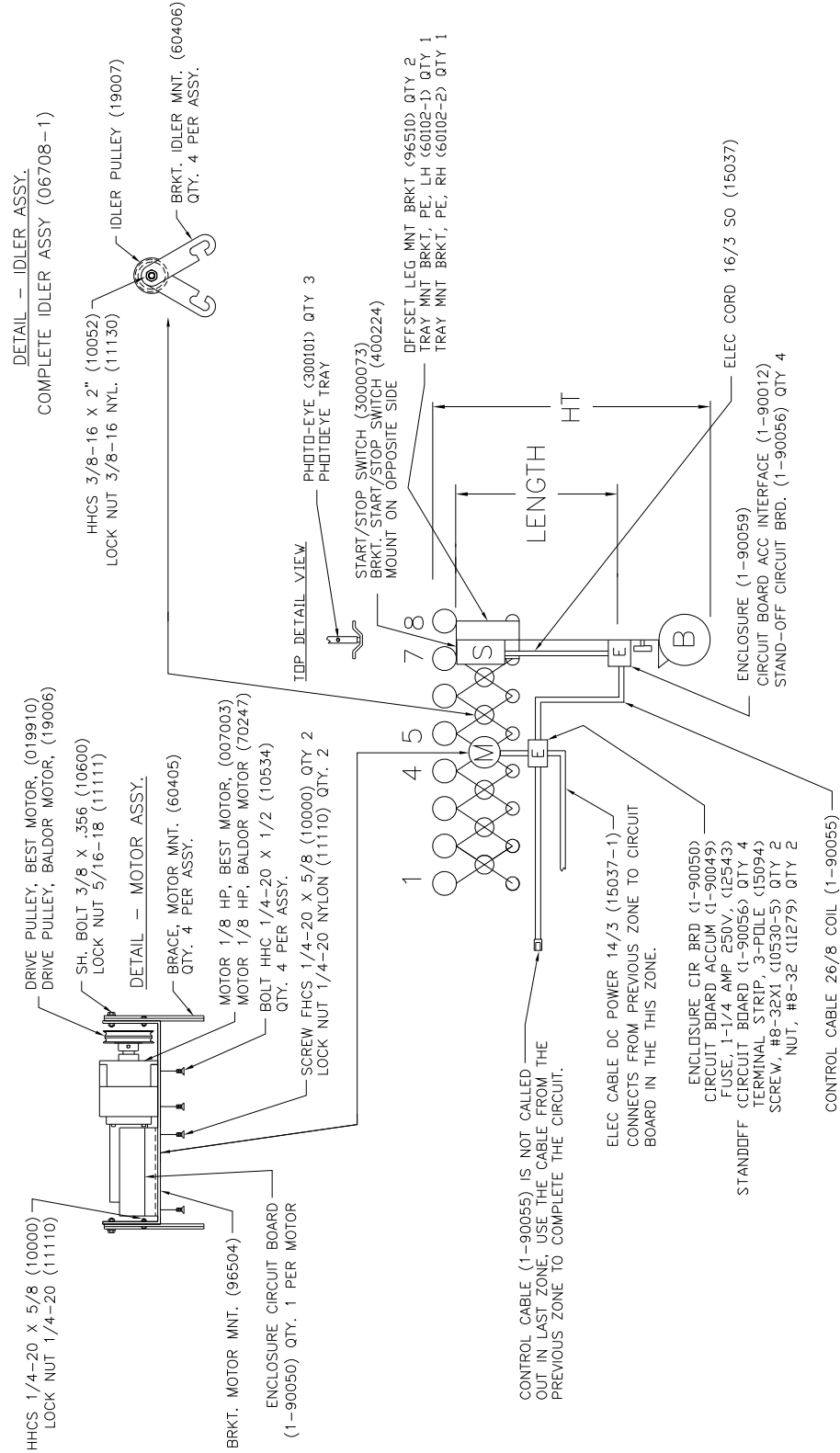

FMH Conveyors Operator's Manual
BestFlex BFP 1.5 and BFP 1.9

Last Zone Parts Lists: Read-Between-Roller Accumulation

1-90049	1	Circuit Board, 2-Way Accum.	15030-5	2	Screw, #8-32 X1
1-90012	1	Interface Board	11279	2	Nut, #8-32
1-90069	4	Spacer, 1/4 HEXx3/4 Leg	60081-PR	As Required	Leg Mount Bracket, 5" or
15037-1	6 Ft.	Electrical Cord, 14/3 SJ 300V	60379-PR	As Required	Leg Mount Bracket, 4" or
1-90055	1	Cable Control 26/8	60375	As Required	Leg Mount Bracket, 3-1/2" or
1-90059	1	Enclosure	60295-PR	As Required	Leg Mount Bracket, 3"
1-90056	4	Stand off, Plastic	60463-5	As Required	Roller Mount Bracket, 5" or
1-90050	1	Enclosure Assembly, Circuit Board	60463-4	As Required	Roller Mount Bracket, 4" or
300101	3	Photo-Eye Sensor Diffuse	60463-35	As Required	Roller Mount Bracket, 3-1/2" or
60102-1	1	Brkt, Tray Mnt, Photoeye, LH	60463-3	As Required	Roller Mount Bracket, 3"
60102-1	1	Brkt, Tray Mnt, Photoeye, LH	50098-ZZ	As Required	Roller 1.5 x ZZ* (SEE NOTE BELOW) or
96510	2	Offset Leg Mount Bracket	50099-ZZ	As Required	Roller 1.9 x ZZ* (SEE NOTE BELOW)
60101-18	1	Photo-Eye Mount Tray, 18" or	95037-ZZ	As Required	Axle 12mm x ZZ* Length, 5/16 THD
60101	1	Photo-Eye Mount Tray, 24" or	10024	As Required	Screw, HHC 5/16-18 x 1/2
60101-30	1	Photo-Eye Mount Tray, 30"	007003	1	Motor, 180V, DC 1/8 HP (0-120 FPM) or
1-90019	3	Strain Relief, .250 Cable	007003	1	Motor, 90V, DC 1/8 HP (0-200 FPM)
12000	4	Washer, Flat, 1/4"	96504	1	Bracket Motor Mount
11110	6	Locknut, Nylon, 1/4"	60405	4	Brace Motor Mount
3000073	1	Start/Stop Motor Control	10000	2	Screw, HHC 1/4-20 x 5/8
15037-11	3 Ft.	Electrical Cord, 18/2	11110	2	Locknut, 1/4-20 Nylon
1-90070	1	Strain Relief, 7P2	10052	6	Screw, HHC 3/8-16 x 2
1-90071	3	Strain Relief, #MP30-1	11130	6	Locknut, 3/8-16 Nylon
1-90072	2	Strain Relief, MP4K1	019910	1	Pulley, Drive, Double Groove
15012-1	3	Strain Relief, 16/3 Wire	19007	As Required	Pulley, Idler, Double Groove
15015	7	Terminal Fork #10, Stud 16-14GAB	60406	As Required	Idler Mount Bracket
60492	As Required	Sidebar, BFP15 or	12466	2	Drive Belt
60507	As Required	Sidebar, BFP19	12467	As Required	Idler Belt
10600	As Required	Sidebar Bolt, 3/8 x 3/8, 5/16 THD	1-90049-S	1	Accumulation Schematic
10620	As Required	Sidebar Bolt, 3/8 x 0.70, 5/16 THD	10015	2	Screw, HHC 1/4-20 x 1-3/4"
10624	As Required	Sidebar Bolt, 3/8 x 1.10, 5/16 THD	10534	4	Bolt, HHC 1/4-20 x 1/2"
11111	As Required	Locknut, Nylon, 5/16	15025	25	Cable Tie, 3/8L, 3/16W
12185	As Required	Spacer, 3/4 OD x 13/32 ID x 0.20	15030-3	8	Screw, #8-32X3/8 RHM
12187	As Required	Washer, Nylon, 1" OD	15097	4	1/2" Cable Clamp Hanger
15094	1	Terminal Strip, 3-Pole	15098	8	Nylon Axle Clamp

Note: ZZ is determined by the unit width and will either be 18, 24, or 30. So, for a BFP1.5 conveyor with that is 24-inches wide, your roller number will be 50098-24 and your axle number will be 95037-24.

Electrical Connection Diagrams

FMH Conveyors Operator's Manual
BestFlex BFP 1.5 and BFP 1.9

Zone Connection Diagram

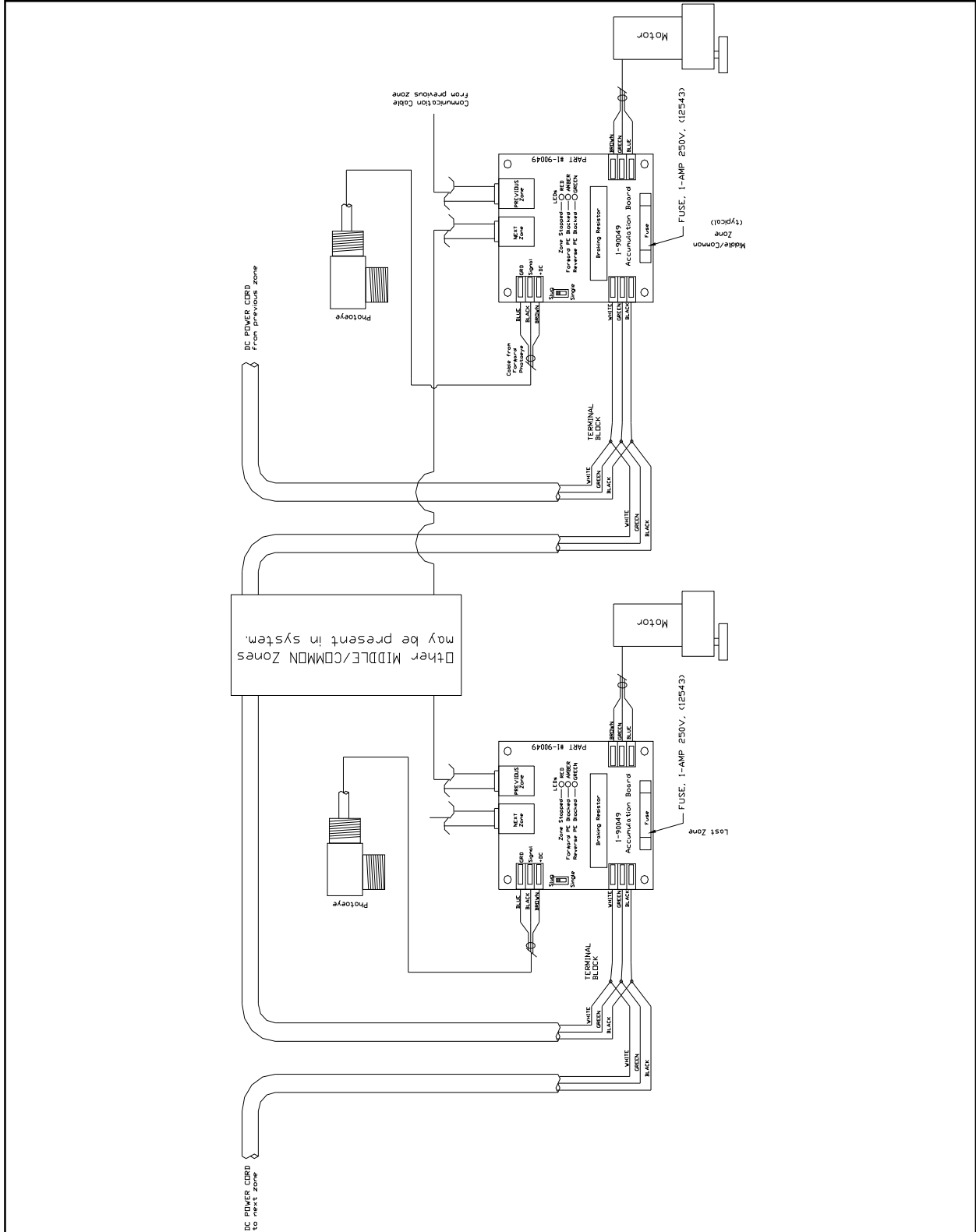

Interface Connection Diagram (Optional)

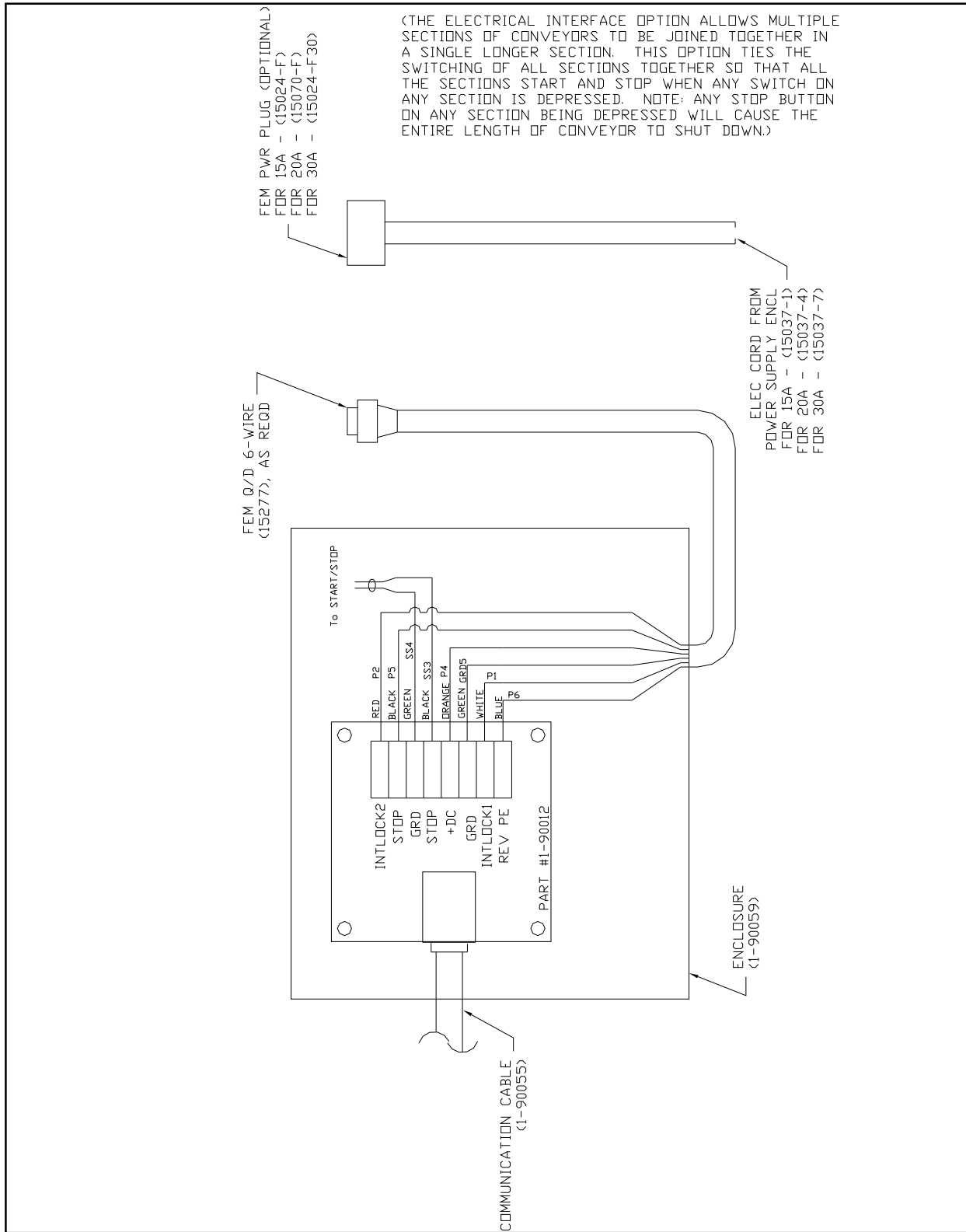

Receiving Interface Connection (Optional)

