

# SYSTEMS ACCESSORIES

## 35 ROLLER TRANSFER

The 35 Roller Transfer is mounted in a Model DC-60 or DCEZ-60 and is used to transfer product from one DC-60 to another DC-60. The 35 Roller Transfer uses 3 1/2" dia x 9 ga. rollers mounted on 6" centers. Air bags lift the transfer mechanism. The 35 Roller Transfer uses a 1/2 HP gearmotor to provide constant 30 FPM.



Shown with Optional 2-Strand Drag Chain.

See DC-60 or DCEZ-60 for Drag Chain Specifications.

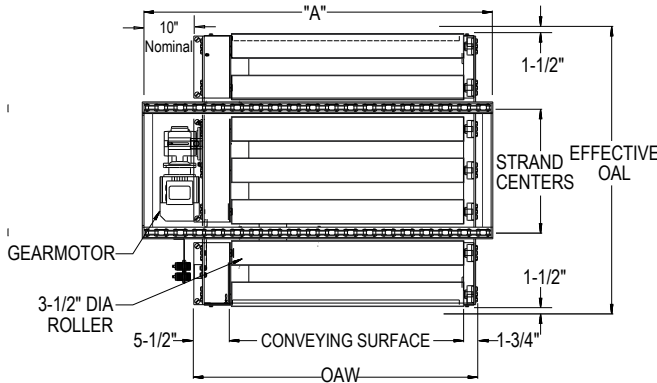

NOTE: Extended Type & Conveyor to Conveyor Type available, contact factory.

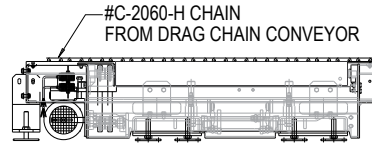

MAXIMUM LOAD 3000 LBS. AT 30 FPM

EFFECTIVE OAL	STRAND CENTERS
42"	18"
48"	24"
54"	30"
60"	36"
66"	42"
72"	48"

OAW	CONVEYING SURFACE	DIM "A"
41"	33 3/4"	51"
44"	36 3/4"	54"
47"	39 3/4"	57"
50"	42 3/4"	60"
53"	45 3/4"	63"
56"	48 3/4"	66"
59"	51 3/4"	69"
62"	54 3/4"	72"
65"	57 3/4"	75"
68"	60 3/4"	78"
71"	63 3/4"	81"
74"	66 3/4"	84"

## 26-CRPT POWER ROTATED TURNTABLE

The 26 CRPT is used to rotate products up to 360 degrees. The turntable is powered by a shaft mounted gearmotor complete with variable speed controller for soft start/stop and has proximity switches mounted on the base to sense position and control rotation of product. Turntable speed is 3 Revolutions per minute with a 1 HP 460/3/60 gearmotor. An 8-wire collector ring allows unlimited rotation of turntable. Powered transition rollers, mounted on apron of turntable deck, help move product onto and off of turntable. The 26 CRR section has a Side Mounted Drive contained within the turning radius of the turntable. Standard speed is 30 FPM with 1/2 HP 460/3/60 gearmotor. The tread rollers are 2 5/8 in. diameter with 7 gauge wall on 4 in. roller centers and have 2 5/8 in. dia. x .219 wall drive rollers with heavy duty bearings. Also available; gravity transition rollers; external transition roller sections (mounted to mating conveyors to fill in gap created by radius of turntable). Minimum Elevation - 16 inches.

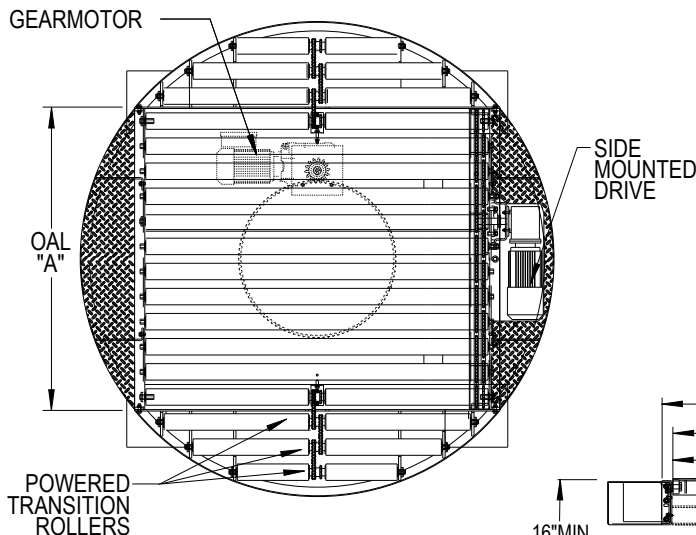

OAL	OAW	BR	CS	WEIGHT
Available in 44" Only	44 1/4"	41"	37 3/4"	1990
	46 1/4"	43"	39 3/4"	2108
	48 1/4"	45"	41 3/4"	2226
	50 1/4"	47"	43 3/4"	2344
	52 1/4"	49"	45 3/4"	2462
	54 1/4"	51"	47 3/4"	2580
	56 1/4"	53"	49 3/4"	2690
	58 1/4"	55"	51 3/4"	2816
	60 1/4"	57"	53 3/4"	2934
	62 1/4"	59"	55 3/4"	3052
	64 1/4"	61"	57 3/4"	3170
	66 1/4"	63"	59 3/4"	3288
	68 1/4"	65"	61 3/4"	3406
70 1/4"	67"	63 3/4"	3524	

All weights in catalog are conveyor weights only. Accessories, crating, etc. are not included

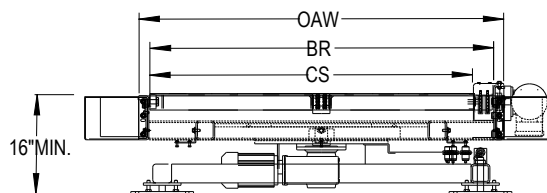

MAXIMUM LOAD 2500 LBS.