

AJUSTEMENTS MACHINE

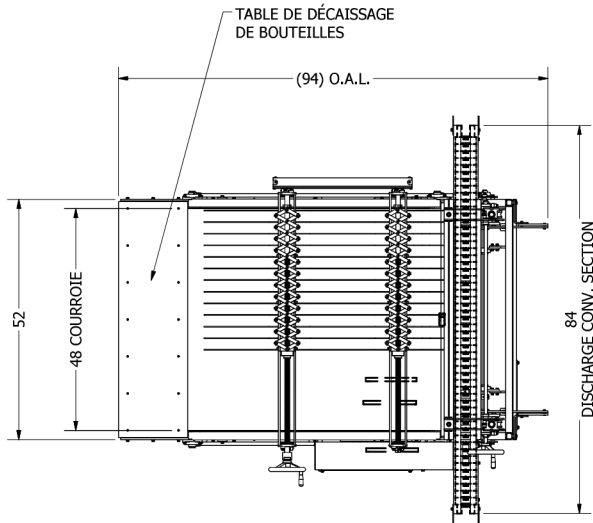



1- VOLANT
AJUSTEMENT LARGEUR
DES RANGÉES DE GUIDES

2- VOLANT
AJUSTEMENT DE LA BUTÉE
DE GOULOT DES BOUTEILLES

3- PANNEAU D'ACCÈS
AJUSTEMENT AVANCE CONVOYEUR

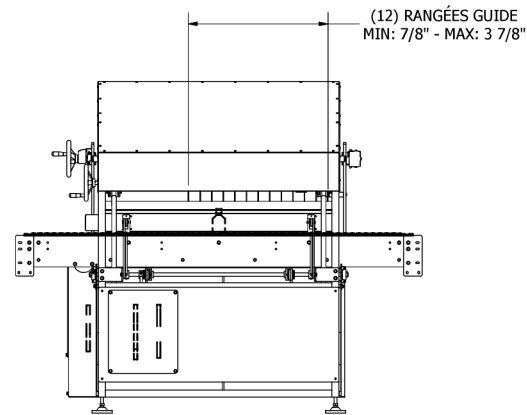
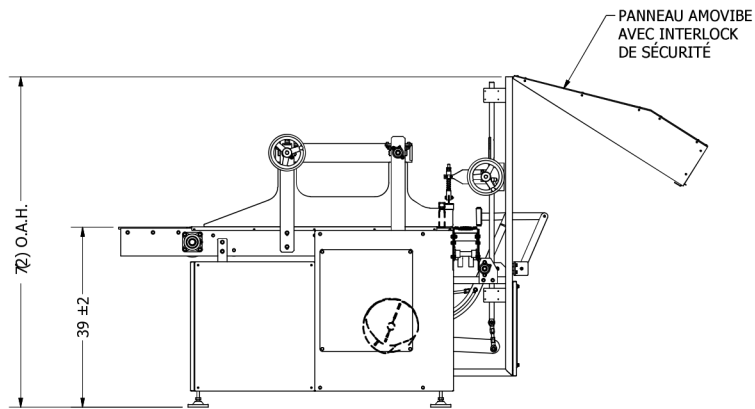
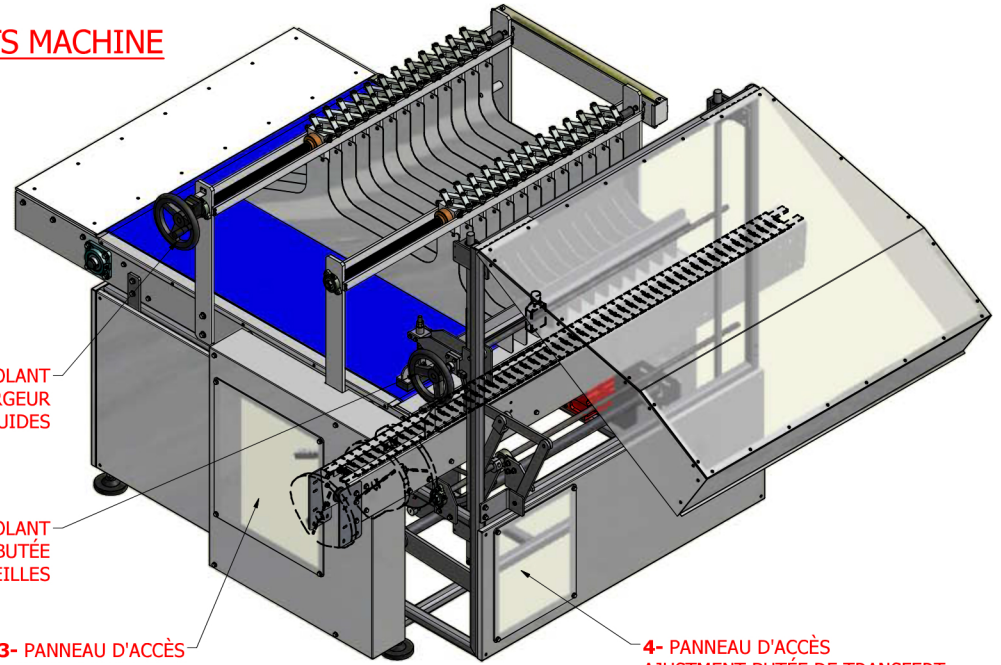
4- PANNEAU D'ACCÈS
AJUSTEMENT BUTÉE DE TRANSFERT



TOLERANCES UNLESS OTHERWISE SPECIFIED		SUBJECT			
ANGLES	± 1'	TITLE			
FRACTIONS	± 1/32"	BOTTLE LANE FEEDER		DWG NO	REV
X	± .030	CUSTOMER	QTY TOT:	DATE	
DECIM. XX	± .015	TRIO1	RH:	LH:	DRAWN
XXX	± .005	JOB #	FINISH	WEIGHT	N/A
ROUGHNESS	✓	EQUIPMENT	BOTTLE LANE FEEDER		SCALE
				SIZE	NTS
				C	SHEET 1 OF 1

TRIO12 -BL - 00