

190-NSPEZC

Live Roller Conveyor (Zero Pressure Accumulating Type)

The 190-NSPEZC Curves are designed to be slave driven from the 190-NSPEZ Conveyor. Curves are used where turns in the conveyor line are necessary.

- EZLogic® Accumulation System
- Singulation, Slug or Cascaded Slug Operation
- Dynamic Zone Allocation
- Positive Brake on All Rollers
- Adjustable MS-Type Floor Supports Available

Between Rail Width	Overall Frame Width	"R"	Total Number of Rollers*				WEIGHTS (Lbs.)			
			90°	60°	45°	30°	90°	60°	45°	30°
13"	16"	24"	16T/4S	10T/4S	8T/12S	5T/12S	202	167	180	152
15"	18"	32 1/2"	20T/4S	12T/4S	10T/12S	6T/12S	251	210	209	173
17"	20"						264	223	218	180
19"	22"						278	236	229	187
21"	24"						290	251	238	196
23"	26"						312	260	249	204
25"	28"						317	273	258	212
27"	30"	48"	28T/4S	20T/4S	14T/12S	10T/12S	332	285	268	222
31"	34"						480	374	346	274
33"	36"						495	386	359	286
37"	40"						529	414	383	299
39"	42"						548	429	395	312



*T = TAPERED S = STRAIGHT
All weights in catalog are conveyor weights only.
Accessories, crating, etc., are not included.

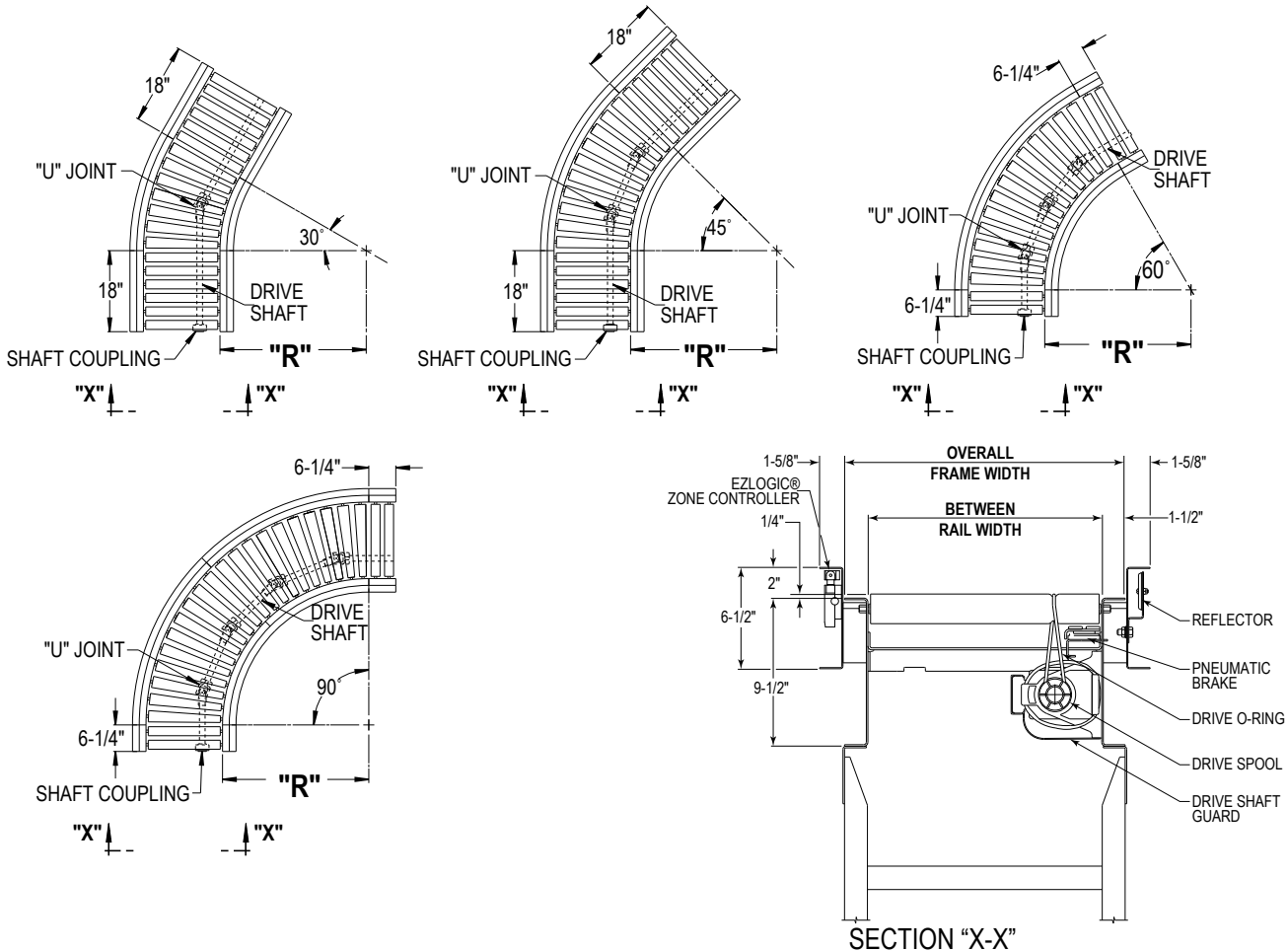

• STANDARD SPECIFICATIONS

190-NSPEZC

BED—Roller bed with 2 1/2 in. dia. tapered to 1 1/4 in. dia. x 14 ga. galvanized and 1.9 in. dia. roller x 16 ga. galvanized tube. Mounted in 9 1/2 in. x 12 ga. powder painted formed steel channel frame.

SLAVE DRIVEN—Curves and spurs are slave driven from drive shaft of Model 190-NSPEZ conveyor. Shafts are coupled by chain coupling at bed joints.

DRIVE SHAFT—1 in. dia. steel shaft extends full length of conveyor, coupled with universal joints (U joints) at necessary intervals.

DRIVE SPOOLS—2 in. dia. Delrin spool held in place on drive shaft with spool spacers.

DRIVE GUARD—Underside of drive shaft with spools and drive o-rings guarded full length of conveyor.

DRIVE O-RING—3/8 in. dia. polyurethane o-ring from drive spool to tread roller.

BEARINGS—Sealed, pre-lubricated, self-aligning, ball bearings with eccentric lock collar on drive shaft. Pre-lubricated ball bearings in tread rollers.

ACCUMULATION ZONES—24 in. long air controlled. 2 per curve.

SPLICE ANGLE—Standard for connecting to 190-NSPEZ or 190-NSP.

CAPACITY—Maximum load see capacity chart below.

FLOOR SUPPORTS—Now supplied as optional equipment.

LOAD CAPACITY CHART		
190-NSPEZC		
Overall Frame Width	Capacity Per Curve	(Lbs.)
16"	150	
18" to 30"	200	
34" to 42"	300	

• STANDARD SPECIFICATIONS

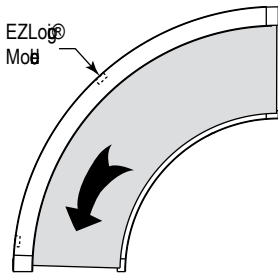

TYPE A
MODULE ON
OUTSIDE OF
THE CURVE
STANDARD

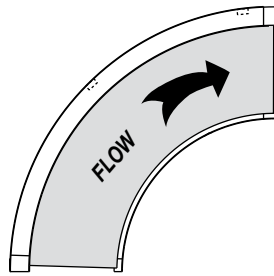

TYPE B
MODULE ON
OUTSIDE OF
THE CURVE
STANDARD

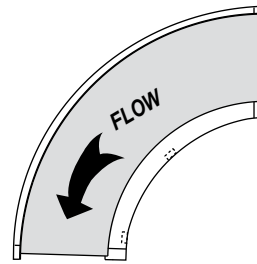

TYPE C
MODULE ON
INSIDE OF THE
CURVE
OPTIONAL

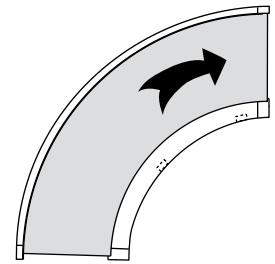

TYPE D
MODULE ON
INSIDE OF THE
CURVE
OPTIONAL

• OPTIONAL EQUIPMENT

FLOOR SUPPORTS—MS Type floor supports are available with a wide range of adjustment. Specify top of belt or roller elevation. One support required at every bed joint and ends of conveyor. Holes in feet for lagging to floor. Knee braces recommended above MS-6 support.

GUARD RAILS—Adjustable Universal Channel Guard Rail, fixed channel or type A or B angle. **Note:** If product comes in contact with guard rails, product flow will be affected.

POLY-TIER SUPPORTS—36 in. to 120 in. support heights in 6 in. increments. Knee braces supplied.

CEILING HANGERS—5/8 in. dia. x 8 ft. long unplated rods fully threaded. Other lengths and galvanized rods available.

EZLogic — See EZLogic Components Page.

