

# 190-E24EZSS

The model 190-E24 24 VDC Live Roller Conveyor uses a series of 24 VDC motors to drive the tread rollers, eliminating the need for drive belts, chains, or line shafts. Quiet operation and ease of maintenance and installation are just some of the advantages.

- EZLogic Accumulation System
- All-Electric Operation (Power Supply Optional)
- Adjustable MS-Type Floor Supports Available

24 VDC 30° Live Roller  
Straight Spur



e24i™

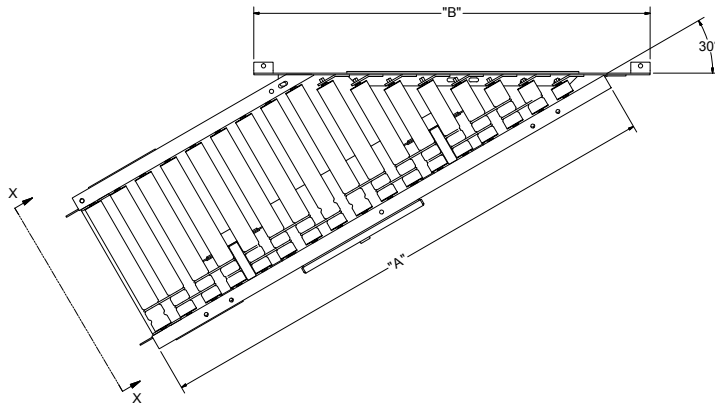

**EZLOGIC**  
U.S. Patent Numbers  
7,243,781 • 7,591,366  
7,905,345 • 6,860,381  
Other Patents Pending.

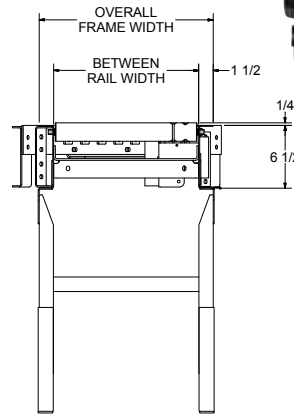

Note: Shown with option floor supports.

## HOW IT WORKS

The conveyor is divided into accumulation zones. Each zone is powered by a 24 VDC Motor. The motor may be turned off to cause product in that zone to stop. Hytrol's EZLogic® Zone Controllers sense product presence and control the accumulation and release of product from the zones.



# 190-E24EZSS

The model 190-E24 24 VDC Live Roller Conveyor uses a series of 24 VDC motors to drive the tread rollers, eliminating the need for drive belts, chains, or line shafts. Quiet operation and ease of maintenance and installation are just some of the advantages.

- EZLogic Accumulation System
- All-Electric Operation
- Adjustable MS-Type Floor Supports Available

24 VDC 45° Live Roller  
Straight Spur

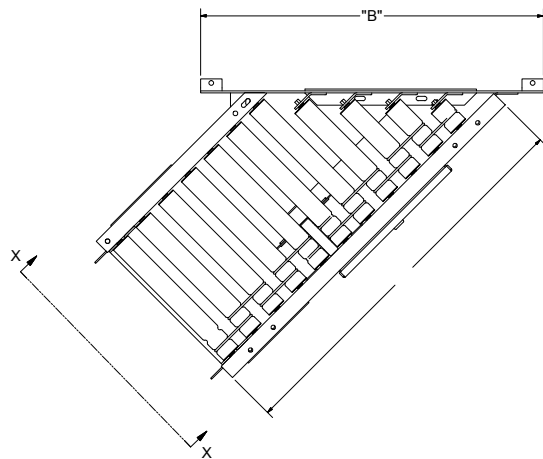

# • STANDARD SPECIFICATIONS

# 190-E24EZSS

**BED**—Roller bed with 1.9 in dia. roller x 16 ga. galvanized tube. Mounted in 6 1/2 in. 12 ga. powder painted formed steel channel frame.

**SLAVE DRIVEN**—Spurs are driven from power supply of Model 190-E24 conveyor. 45° spur has (1) 24 VDC motor with integrated motor control card, 30° spur has (1) 24 VDC motor with integrated motor control card on 12"-16" OAW, and (2) VDC motor with integrated motor control card on 18"-42" OAW. Motors mounted on the inside of the B.R.

**SLAVE O-RING**—3/16 in. dia. polyurethane o-ring from drive spool to tread roller.

**ACCUMULATION ZONES**—1 per spur with zone controller (retro-reflective)

**BEARINGS**—Pre-lubricated ball bearings in tread rollers.

**SPLICE PLATES**—Standard for connecting to 190-E24.

**CAPACITY**—See Load Capacity Chart.

**FLOOR SUPPORTS**—Now supplied as optional equipment.

Between Rail Width	Overall Frame Width	"A"		"B"		WEIGHTS (Lbs.)	
		45°	30°	45°	30°	45°	30°
9"	12"	21"	30"	23"	29"	177	224
11"	14"	21"	30"	26"	35"	182	230
13"	16"	21"	30"	29"	38"	188	235
15"	18"	36"	54"	32"	41"	193	241
17"	20"	36"	54"	35"	47"	198	247
19"	22"	36"	54"	38"	50"	203	253
21"	24"	36"	54"	41"	53"	209	258
23"	26"	36"	54"	44"	56"	214	264
25"	28"	36"	54"	47"	62"	219	270
27"	30"	36"	54"	50"	65"	224	276
31"	34"	48"	75"	56"	74"	235	287
33"	36"	48"	75"	59"	77"	240	393
37"	40"	48"	75"	65"	86"	251	304
39"	42"	48"	75"	68"	89"	256	310

All weights in catalog are conveyor weights only. Accessories, crating, etc., are not included.

LOAD CAPACITY CHART		
Overall Length	190-E24EZSS	
	Capacity Per Spur	
	45°	30°
21"	65	
36"	111	
48"	148	
30"		92
54"		166
75"		231

# • OPTIONAL EQUIPMENT

**FLOOR SUPPORTS**—MS Type floor supports are available with a wide range of adjustment. Specify top of belt or roller elevation. One support required at every bed joint and ends of conveyor. Holes in feet for lagging to floor. Knee braces recommended above MS-6 support.

**POWER SUPPLY FOR MOTORS**—40, 20, and 5 AMP available in 115, 230, or 460 volt

**HIGH SPEED DRIVE SPOOL**—Provides a speed range of 50-200 FPM Capacity affected with speed change.

**DRIVE**—Motors mounted on the inside of the frame channel.

**GUARD RAILS**—Adjustable Universal Channel Guard Rail, fixed channel or type A or B angle. **Note:** If product comes in contact with guard rails, product flow will be affected.

**POLY-TIER SUPPORTS**—36 in. to 120 in. support heights in 6 in. increments. Knee braces supplied.

**CEILING HANGERS**—3/8 in. dia. x 8 ft. long unplated rods fully threaded. Other lengths and galvanized rods available.

**MOTOR AND SEPARATE CONTROL CARD**— Available with 3 Amp setting.

