

190-NSPC

The 190 Spool Curves and Spurs are designed to be slave driven from the 190-NSP Conveyor. Curves are used where turns in the conveyor line are necessary. Spurs are used in diverging and converging applications.

- 12 Bed Widths
- Slave Driven from Model 190-NSP
- Adjustable MS-Type Floor Supports Available

Between Rail Width	Overall Frame Width	"R"	Total Number of Rollers*				WEIGHTS (Lbs.)			
			90°	60°	45°	30°	90°	60°	45°	30°
13"	16"	24"	16T/4S	10T/4S	8T/12S	5T/12S	179	144	157	132
15"	18"						222	184	183	151
17"	20"						235	197	192	158
19"	22"						248	209	202	165
21"	24"						259	224	211	173
23"	26"						281	233	222	181
25"	28"	32 1/2"	20T/4S	12T/4S	10T/12S	6T/12S	285	246	231	189
27"	30"						299	258	241	199
31"	34"						437	338	313	247
33"	36"						452	353	326	259
37"	40"						484	380	349	271
39"	42"						503	395	361	285
		48"	28T/4S	20T/4S	14T/12S	10T/12S	503	395	361	285

*T = TAPERED

S = STRAIGHT

All weights in catalog are conveyor weights only. Accessories, crating, etc., are not included.

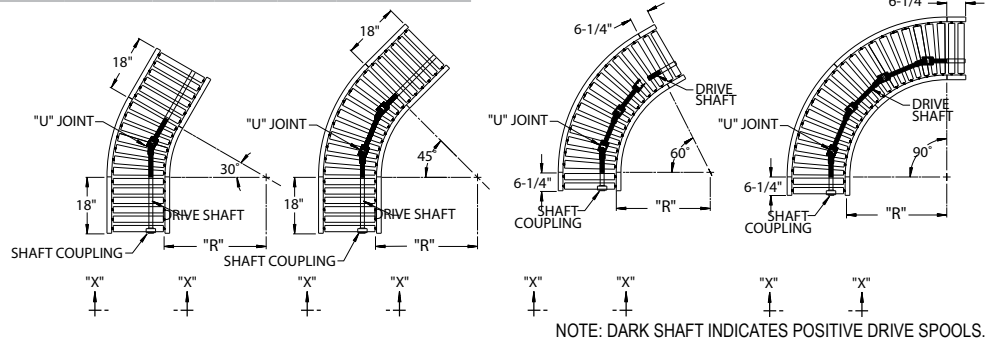
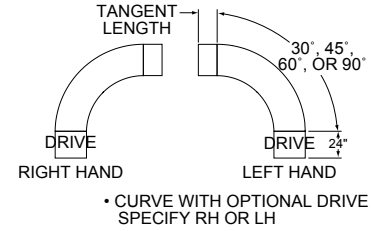

190-NSPS

Between Rail Width	Overall Frame Width	"R"	"A"		"B"		"C"		"D"		"E"		Number of Rollers*		WEIGHTS (Lbs.)		
			45°	30°	45°	30°	45°	30°	45°	30°	45°	30°	45°	30°	45°	30°	
13"	16"	24"	29"	38"	27"	36"	21"	30"	21 7/8"	38"	50"	42 1/4"	8T/12S	10T/11S	173	176	
15"	18"		32"	41"	30"	39"										230	263
17"	20"		35"	47"	33"	45"										240	274
19"	22"		38"	50"	36"	48"										250	283
21"	24"		41"	53"	39"	51"	36"	54"	35"	63"	66 5/8"	61 3/8"	10T/17S	12T/19S	259	293	
23"	26"		44"	56"	42"	54"										268	303
25"	28"	32 1/2"	47"	62"	45"	60"									280	316	
27"	30"		50"	65"	48"	63"										288	325
31"	34"		56"	74"	54"	72"										410	499
33"	36"		59"	77"	57"	75"										422	513
37"	40"		48"	65"	86"	63"	84"	48"	75"	48"	89"	86"	85 1/2"	14T/21S	20T/26S	446	540
39"	42"			68"	89"	66"	87"										457

*T = TAPERED

S = STRAIGHT

All weights in catalog are conveyor weights only. Accessories, crating, etc., are not included.

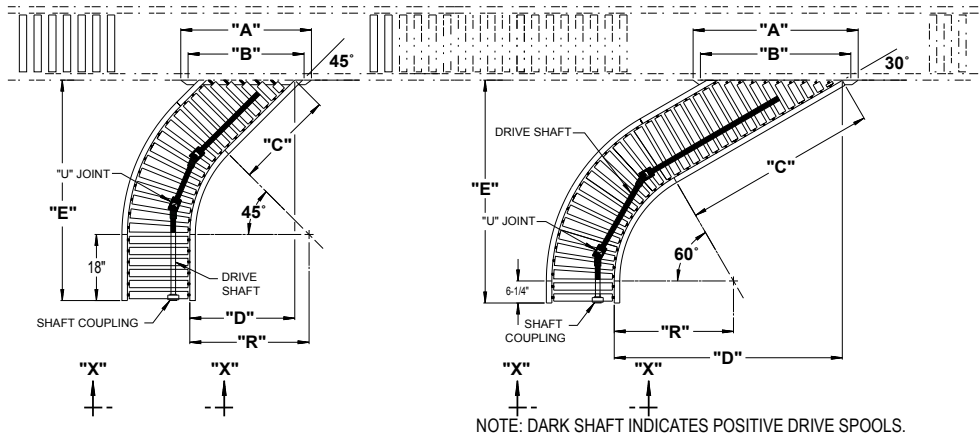
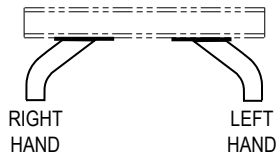
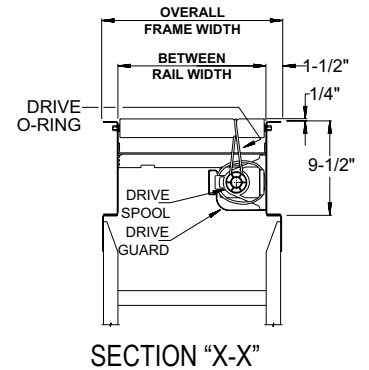

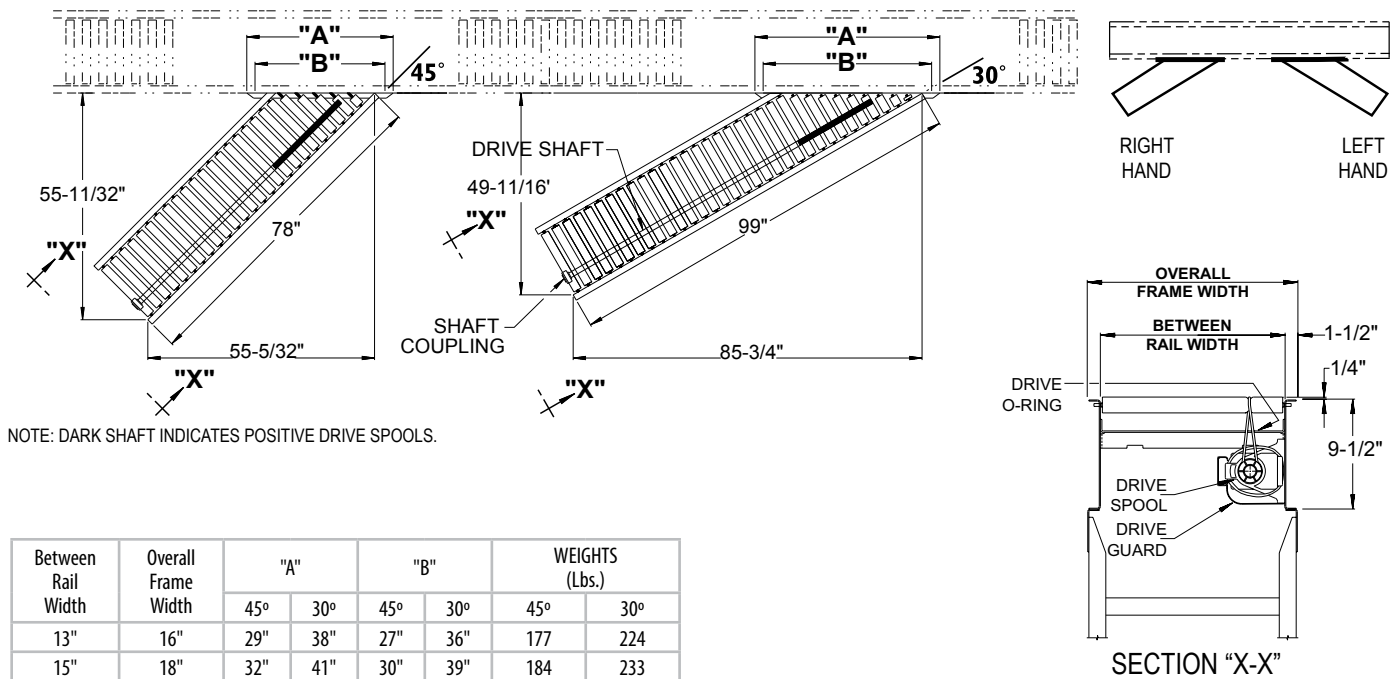

NOTE: DARK SHAFT INDICATES POSITIVE DRIVE SPOOLS.

Between Rail Width	Overall Frame Width	"A"		"B"		WEIGHTS (Lbs.)	
		45°	30°	45°	30°	45°	30°
13"	16"	29"	38"	27"	36"	177	224
15"	18"	32"	41"	30"	39"	184	233
17"	20"	35"	47"	33"	45"	191	241
19"	22"	38"	50"	36"	48"	198	249
21"	24"	41"	53"	39"	51"	204	256
23"	26"	44"	56"	42"	54"	210	262
25"	28"	47"	62"	45"	60"	219	272
27"	30"	50"	65"	48"	63"	225	278
31"	34"	56"	74"	54"	72"	237	290
33"	36"	59"	77"	57"	75"	242	296
37"	40"	65"	86"	63"	84"	253	306
39"	42"	68"	89"	66"	87"	256	310

All weights in catalog are conveyor weights only. Accessories, crating, etc., are not included.

Overall Frame Width	LOAD CAPACITY CHART				
	190-NSPC Capacity Per Curve (Lbs.)	190-NSPS Capacity Per Spur (Lbs.)		190-NSPSS Capacity Per St. Spur (Lbs.)	
		45°	30°	45°	30°
16"	240	300	285		
18" to 30"	300	405	435	375	480
34" to 42"	450	540	720		

• STANDARD SPECIFICATIONS

BED—Roller bed with 2 1/2 in. dia. tapered to 1 1/16 in. dia. x 14 ga. galvanized and 1.9 in. dia. roller x 16 ga. galvanized tube. Mounted in 9 1/2 in. x 12 ga. powder painted formed steel channel frame.

SLAVE DRIVEN—Curves and spurs are slave driven from drive shaft of Model 190-NSP conveyor. Shafts are coupled by chain coupling at bed joints.

DRIVE SHAFT—1 in. dia. steel shaft extends full length of conveyor, coupled with universal joints (U joints) at necessary intervals.

DRIVE SPOOLS—2 in. dia. Delrin spool held in place on drive shaft with spool spacers.

DRIVE GUARD—Underside of drive shaft with spools and drive o-rings guarded full length of conveyor.

DRIVE O-RING—3/16 in. dia. polyurethane o-ring from drive spool to tread roller.

BEARINGS—Sealed, pre-lubricated, self-aligning, ball bearings with eccentric lock collar on drive shaft. Pre-lubricated ball bearings in tread rollers.

SPLICE PLATES—Standard for connecting to 190-NSP.

CAPACITY—See Load Capacity Chart.

FLOOR SUPPORTS—Now supplied as optional equipment.

• OPTIONAL EQUIPMENT

FLOOR SUPPORTS—MS Type floor supports are available with a wide range of adjustment. Specify top of belt or roller elevation. One support required at every bed joint and ends of conveyor. Holes in feet for lagging to floor. Knee braces recommended above MS-6 support.

CONVEYING SPEED—Other constant and variable speeds from 30 to 120 FPM. Over 120 FPM timing belt drive recommended. Capacity affected with speed change.

DRIVE—24 in. long drive section replaces standard 6 1/4 in. or 18 in. tangent on end of 190-NSPC or 190-NSPS. No change on 190-NSPSS. Specify RH or LH.

GUARD RAILS—Adjustable Universal Channel Guard Rail, fixed channel or type A or B angle. **Note:** If product comes in contact with guard rails, product flow will be affected.

POLY-TIER SUPPORTS—36 in. to 120 in. support heights in 6 in. increments. Knee braces supplied.

CEILING HANGERS—5/8 in. dia. x 8 ft. long unplated rods fully threaded. Other lengths and galvanized rods available.

OPTIONAL TANGENTS—Available in 3 in. increments up thru 48 in. long.