

25-PVR

Poly-V Belt Driven Live Roller Conveyor (Roll-to-Roll Type)

The heavy design of the 25-PVR allows it to be used for conveying higher load capacities such as loaded pallets and drums. Poly-V belt driven rollers make it ideal for conveying heavier parts where little maintenance or a quieter conveyor is required.

- 15 Bed Widths
- Shaft Mounted Drive
- Reversible
- Poly-V Belt Driven Rollers
- Adjustable HSN-Type Floor Supports Available



Conveyor shown with optional floor supports

3 in., 4 in., and 6 in. Roller Centers

Conveying Surface	15 3/4"	17 3/4"	19 3/4"	21 3/4"	23 3/4"	27 3/4"	29 3/4"	33 3/4"	35 3/4"	39 3/4"	43 3/4"	47 3/4"	51 3/4"	57 3/4"	63 3/4"
Between Rail Width	19"	21"	23"	25"	27"	31"	33"	37"	39"	43"	47"	51"	55"	61"	67"
Overall Frame Width	22 1/4"	24 1/4"	26 1/4"	28 1/4"	30 1/4"	34 1/4"	36 1/4"	40 1/4"	42 1/4"	46 1/4"	50 1/4"	54 1/4"	58 1/4"	64 1/4"	70 1/4"
3" Centers 10' Length-O.A.	862	890	918	946	974	1030	1058	1114	1142	1198	1254	1310	1366	1450	1534
Per Foot	72	75	78	81	84	90	93	99	102	108	114	120	126	135	144
4" Centers 10' Length-O.A.	722	750	778	806	834	890	918	974	1002	1058	1114	1170	1226	1310	1394
Per Foot	61	64	67	70	73	79	82	88	91	97	103	109	113	124	133
6" Centers 10' Length-O.A.	582	610	638	666	694	750	778	834	862	918	974	1030	1086	1170	1254
Per Foot	49	52	55	58	61	67	70	76	79	85	91	97	103	112	121

- All weights in catalog are conveyor weights only. Accessories, crating, etc. are not included
- Motors will slave a maximum of 40 rollers, 20 rollers per side.

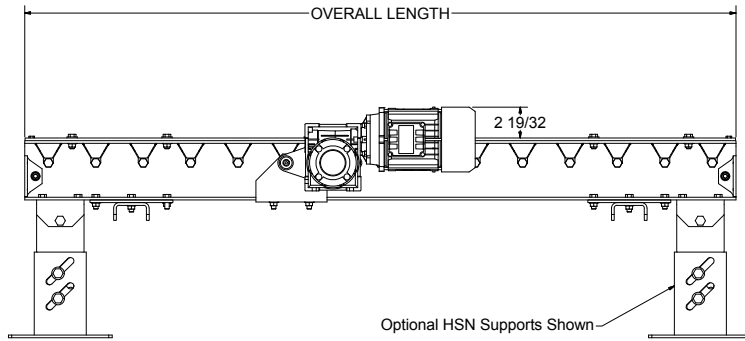

VIEW A-A
SCALE 1:5

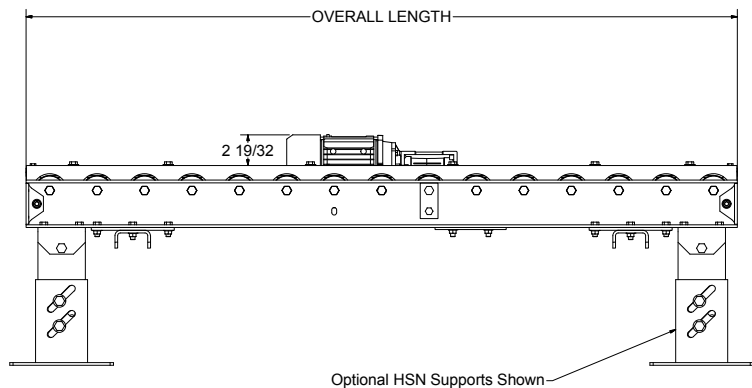
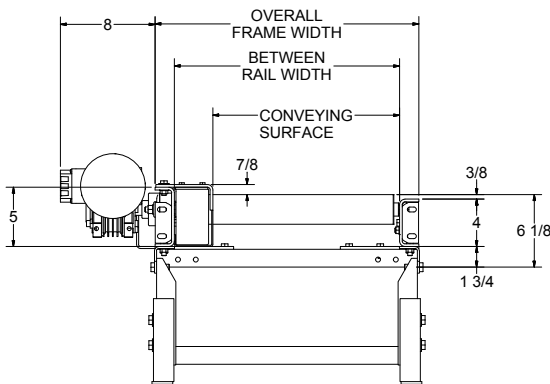

• STANDARD SPECIFICATIONS

BED—Roller bed with 2 ½ in. dia. x 11 ga. unplated tread rollers spaced every 3 in., 4 in., or 6 in. roller centers only. Tread rollers mounted in 4 in. x 4 ga. powder painted formed steel channel on side opposite guard and 5 in. x 4 ga. powder painted formed steel channel on guard side.

SHAFT MOUNTED DRIVE—Shaft mounted drive to the side of the bed section.

POLY-V BELT—8-rib J-Profile roller to roller.

GUARD—Formed steel, upper and lower guard mounted to top and bottom of channel frame to totally enclose drive belts.

BEARINGS—Sealed, pre-lubricated ball bearings.

MOTOR—1 HP—208/230/460/575V—3 Ph. 60 Hz. gearmotor.

CONVEYING SPEED—Constant 30 FPM.

CAPACITY—Maximum load per linear foot of conveyor 300 lb. with supports on 10 ft. centers, 1000 lb. with supports on 5 ft. centers. Total load 3000 lbs.

FLOOR SUPPORTS—Now supplied as optional equipment.

CONVEYOR LENGTHS—Maximum 10' per drive.



GUARD REMOVED TO ILLUSTRATE ROLL TO ROLL DRIVE BELT.

WARNING: DO NOT OPERATE CONVEYOR WITH GUARD REMOVED.

• OPTIONAL EQUIPMENT

FLOOR SUPPORTS—HSN Type floor supports are available with a wide range of adjustment. Specify top or roller elevation. One support required at every bed joint and ends of conveyor. Holes in feet for lagging to floor. Knee braces recommended above HSN-3 support.

CONVEYING SPEED—Other constant and variable speeds. **NOTE:** Capacity affected with speed change.

GUARD RAILS—Fixed angle (2 in. high x ¼ in. steel) guard bolts to top flange of channel opposite guard.

CHANNEL END STOP—6" x 8.2 lb. structural channel end stop.

TRANSFERS—Chain transfers available. See Accessory section.

MOTORS—Other HP gearmotors available.

ELECTRICAL CONTROLS—Non-reversing magnetic starter — push-button stations. AC variable frequency drive.