

# 199-PVR

## Poly-V Belt Driven Live Roller Conveyor

The Model 199-PVR is a medium-duty poly-v belt driven live roller conveyor. The roll-to-roll belt drive makes this conveyor ideal for light duty pallet handling where little maintenance or a quieter conveyor is desirable.

- 11 Bed Widths
- Shaft Mounted Drive
- Reversible
- Poly-V Belt Driven Rollers
- Adjustable MSN-Type Floor Supports Available



Conveyor shown with optional floor supports

Conveying Surface	12 1/4"	14 1/4"	16 1/4"	18 1/4"	20 1/4"	22 1/4"	24 1/4"	28 1/4"	30 1/4"	34 1/4"	36 1/4"
Between Rail Width	15"	17"	19"	21"	23"	25"	27"	31"	33"	37"	39"
Overall Frame Width	18"	20"	22"	24"	26"	28"	30"	34"	36"	40"	42"
3" Centers 10' Length-O.A.	705	740	765	790	825	850	885	935	970	1010	1055
Per Foot	56	59	61	63	66	68	71	75	78	81	85
4" Centers 10' Length-O.A.	655	680	705	730	755	780	805	855	870	920	955
Per Foot	51	53	55	57	59	61	63	67	69	72	75
6" Centers 10' Length-O.A.	605	620	645	670	685	710	725	775	780	830	855
Per Foot	46	47	49	51	52	54	55	59	60	63	65

- All weights in catalog are conveyor weights only. Accessories, crating, etc. are not included
- Motors will slave a maximum of 40 rollers, 20 rollers per side.

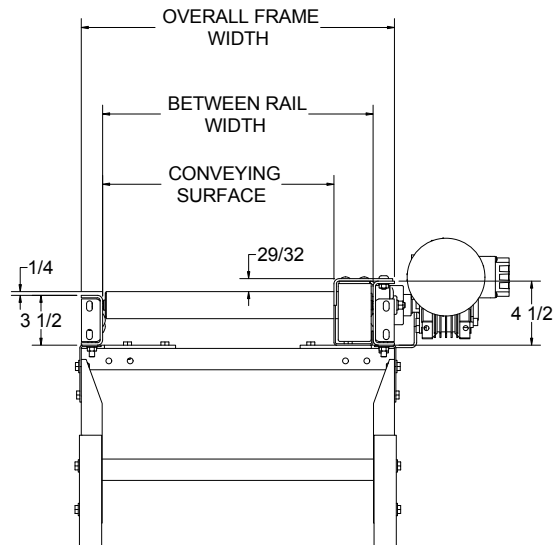
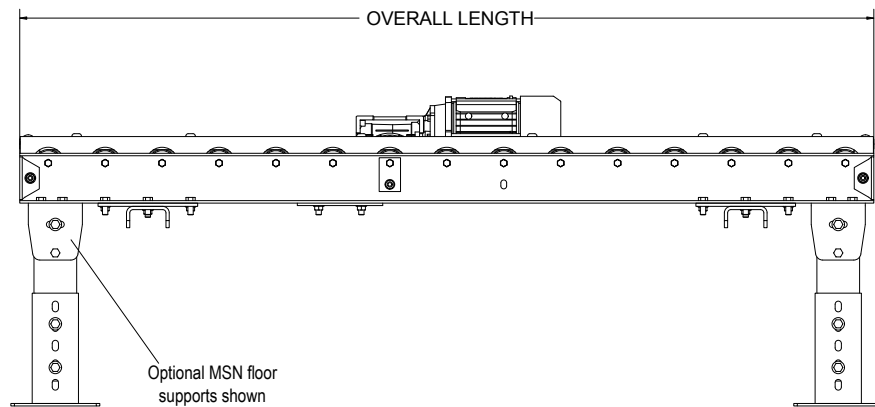

## • STANDARD SPECIFICATIONS

**BED**—Roller bed with 1.9 in. x 9 ga. wall unplated tread rollers spaced every 3 in, 4 in, or 6 in mounted in 7 ga. powder painted formed steel channel frame bolted together with butt couplings.

**SHAFT MOUNTED DRIVE**—Shaft mounted gearmotor to the side of the bed section.

**POLY-V BELT**—4-rib J-Profile roller to roller

**GUARD**—Mounted to top of channel frame to totally enclose drive belts.

**BEARINGS**—Sealed, pre-lubricated ball bearings on drive roller shaft.

**MOTOR**—½ HP—208/230/460/575V—3 Ph. 60 Hz. Gearmotor.

**CONVEYING SPEED**—Constant 35 FPM.

**CAPACITY**—Maximum load per linear foot of conveyor 150 lbs with supports on 10' centers, 250 lbs with supports on 5' centers. 600 lbs total load.

**FLOOR SUPPORTS**—Now supplied as optional equipment.

**CONVEYOR LENGTH**—Maximum 10' per drive.



GUARD REMOVED TO ILLUSTRATE ROLL TO ROLL DRIVE BELT.

WARNING: DO NOT OPERATE CONVEYOR WITH GUARD REMOVED.

## • OPTIONAL EQUIPMENT

**FLOOR SUPPORTS**—MSN Type floor supports are available with a wide range of adjustment. Specify top of belt or roller elevation. One support required at every bed joint and ends of conveyor. Holes in feet for lagging to floor. Knee braces recommended above MSN-6 support.

**CONVEYING SPEED**—Other constant and variable speeds. **NOTE:** Capacity affected with speed change.

**GUARD RAILS**—Adjustable Universal Channel Guard Rail, (both sides) fixed channel (both sides) or angle (one side). See Accessory section.

**POLY-TIER SUPPORTS**—36 in. to 120 in. support heights in 6 in. increments. Knee braces supplied.

**CEILING HANGERS**—½ in. dia. x 8 ft. long unplated rods fully threaded. Other lengths and galvanized rods available.

**MOTORS**—Other HP gearmotors available.

**ELECTRICAL CONTROLS**—Non-reversing magnetic starters and push-button stations. AC variable frequency drive.

**TRANSFERS**—Chain transfers available. See accessories.